

# Position of the NCal relative to the reference plates for O4. VIR-1009B-22

Eddy Dangelser, Dimitri Estevez, Benoit Mours, Mehmet Ozturk, Antoine Syx,  
Valeria Zeter

IPHC-Strasbourg

November 21, 2022

## Contents

<b>1</b>	<b>Introduction</b>	<b>2</b>
<b>2</b>	<b>Measurements</b>	<b>3</b>
2.1	Distance between the reference hole and the NCal rods . . . . .	3
2.2	Distance between the NCal rods . . . . .	6
2.3	Measurements of the NCal axis offset from the NCal rods . . . . .	7
<b>3</b>	<b>Effects of a possible horizontal tilt defect</b>	<b>8</b>
<b>4</b>	<b>Computing the distance from each NCal axis to their reference hole</b>	<b>8</b>
4.1	Layout of the NCal setups . . . . .	8
4.2	Values and uncertainties . . . . .	9

## 1 Introduction

The NCal system around the NE tower is made of three setups. One NCal setup is composed of a reference plate and two NCals mounted on a suspended vertical plate. Drawings are available at the end of this note.

Three reference plates have already been installed around the NE tower as explained in [VIR-1123A-21](#) and their position in the Virgo Reference System (VRS) has been determined in [VIR-0343A-22](#).

Three suspended plates have also been installed around the NE tower (see logbook entry [55110](#)). Figure 2 shows one of the suspended plates that is used to place NCals around the mirror. Each suspended plate can hold up to three NCals (but only two of them could be connected to the electronic at the same time) which are mounted on NCal rods circled in red on the figure, labelled L for left, C for center and R for right.

The purpose of this technical note is to describe how the distance between the NCal axes and the reference holes is determined (see fig. 1). For this we need to measure the distance between a NCal rod and a reference hole (labelled as 2 in fig. 3), the distance between the NCal rods and the NCals axis offset to the NCal rods (labelled as L, C and R in fig. 2). The distances we are considering here are the distances projected on the horizontal plane. The effect of changing the plane will be discussed in a following section.

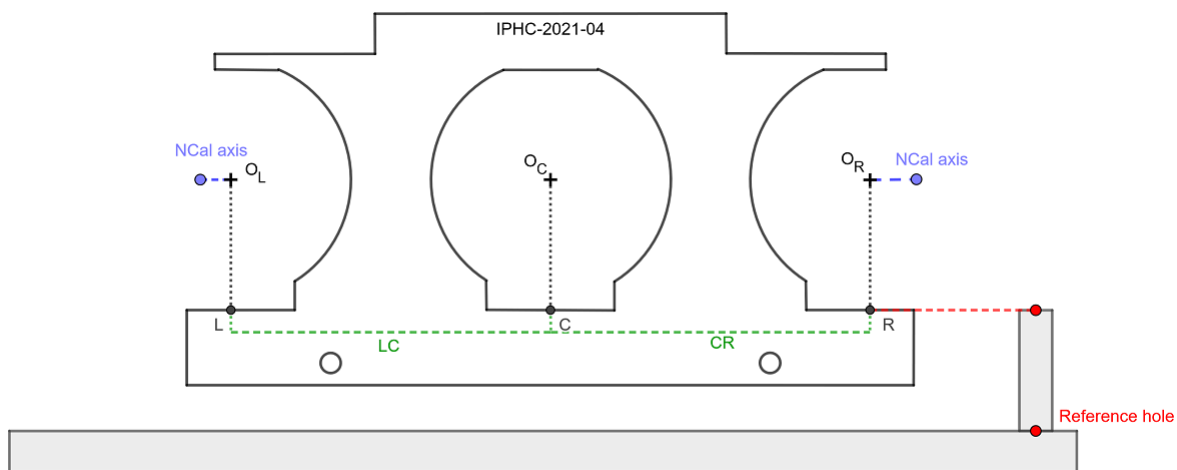

Figure 1: Outline of the front face of the North vertical plate suspended on a reference plate, the distances and offsets that will be measured are represented as dashed colored lines.

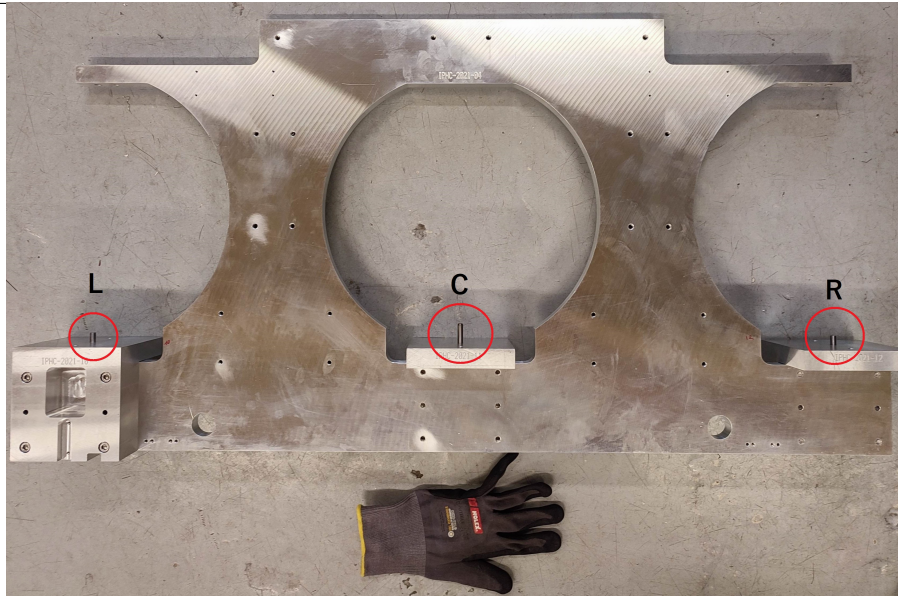

Figure 2: Front face of one of the suspended plates for O4, the labelled front face is marked "IPHC-2021-04". The NCal rods are circled in red and are labelled L for left, C for center and R for right.

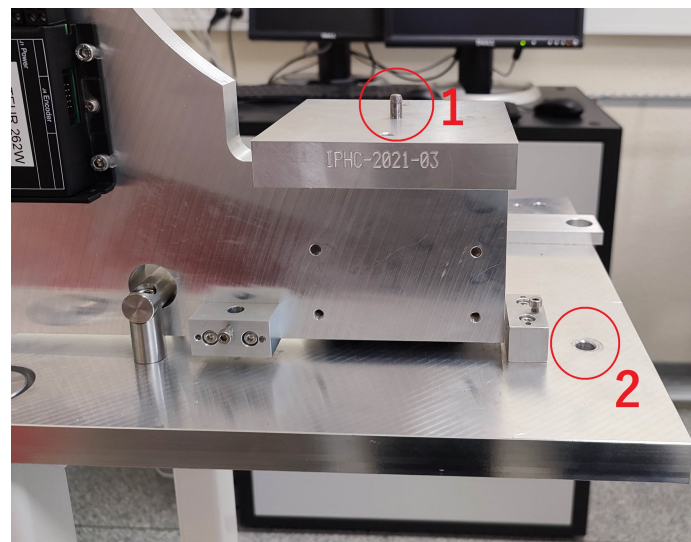

Figure 3: (1) right NCal rod of one of the suspended plate. (2) a reference hole on a reference plate.

## 2 Measurements

### 2.1 Distance between the reference hole and the NCal rods

This section concerns the distance between the reference hole and the NCal rods on the suspended plate. We set the distance between the external NCal rod from a reference hole by using a template when no NCal is installed.

The template is shown in fig. 4, it is composed of a metal bar and a small aluminum plate which have two holes to fit both the metal bar and the NCal rod. For the purpose of this measurement, three metal bars and small aluminum plates have been machined. The installation process is shown in fig. 5, as we can see the metal bar has the purpose to place the small aluminum plate in an horizontal plane.

We used small flat plates as spacers to hold the suspended plate still along the lateral and vertical directions as shown in fig. 6. Once the template is installed and the setup is still, the data coming from the position sensors is read. After switching between the different templates and adjusting the setup back in a still position we observed that the greatest axial variation obtained for a single measurement was  $\pm 0.1$  mm around a mean value. Then after two or three measurement we could obtained a variation of  $\pm 0.05$  mm. When swapping the vertical rod and/or the template, the results remain the same.



Figure 4: The two parts of a template used. On the left is a small aluminum plate on the right is a metal bar.

In addition, once the setup is still, we removed the small aluminum plate from the template leaving the NCal rod and the metal bar, the position sensor readout remains the same within  $\pm 0.02$  mm. This value is negligible compared to the previous variation of 0.05 mm. The metal bar is 125 mm of height, the part that fits in the reference hole is not taken into account in the measurement. The machining error between the two holes is 0.01 mm.

The distance between the external NCal rod and the reference hole is then  $100.00 \pm 0.05$  mm.



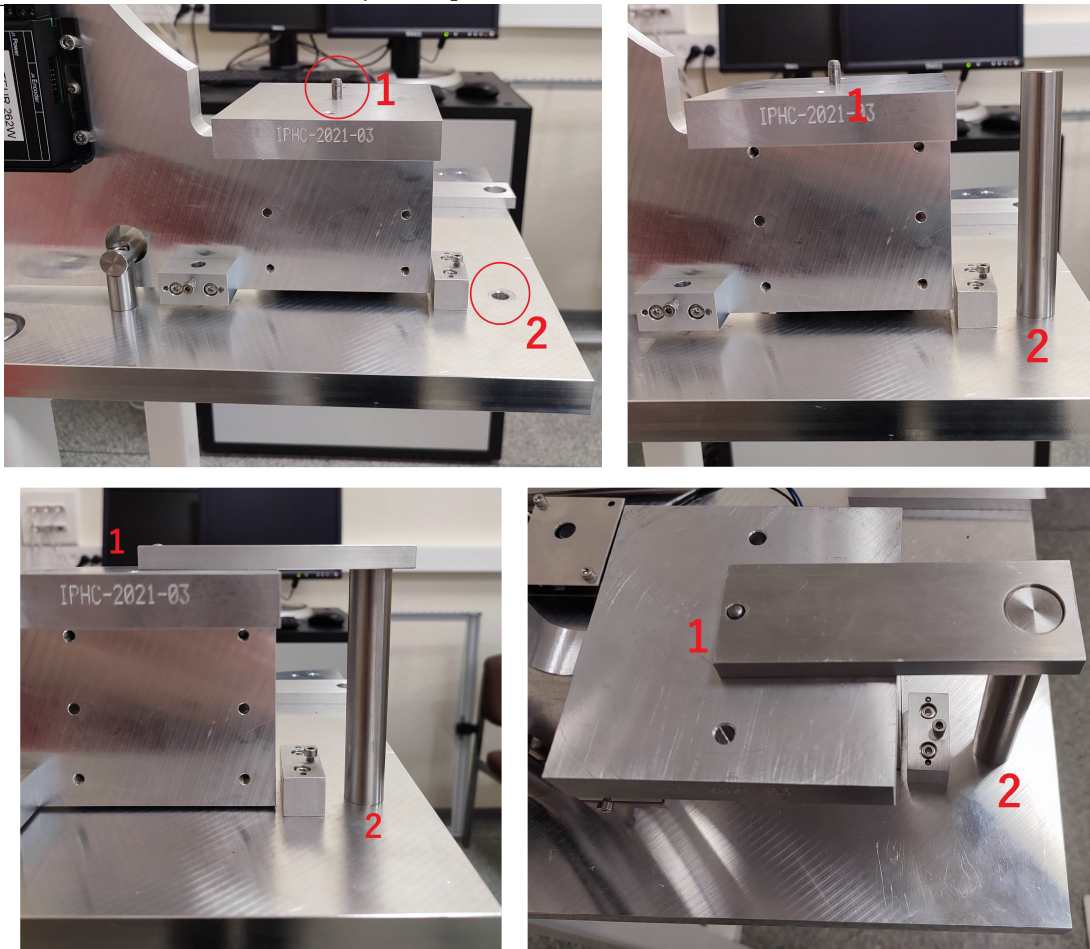

Figure 5: Installation of the template to set the distance between the NCal rod on the suspended plate (1) and the reference hole on the reference plate (2). The installation process is shown top to bottom and left to right.

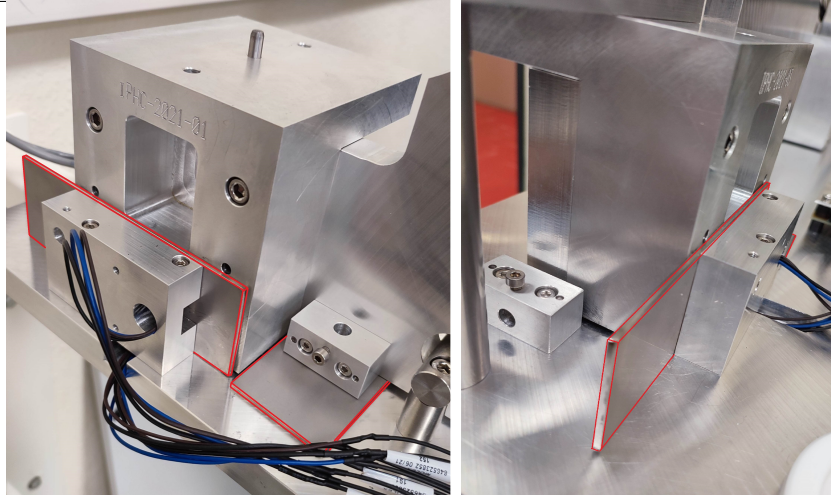

Figure 6: Flat metal plates used as spacers outlined in red.

## 2.2 Distance between the NCal rods

Theoretically there is 40 cm between each NCal rod. These distances have been measured using a 1 m vernier caliper with a precision of  $20\ \mu\text{m}$  as shown in fig. 7. As the measurements were made using a vernier caliper, the tool was used from one side of an NCal rod to the other side of the next NCal rod. Several measurements over the NCal rods revealed that they are approximately 6.04 mm in diameter, this value is taken into account in the table.

Table 1 shows the measured value of the distance between the NCal rods on the suspended plates, LC stands for left-center distance, CR for center-right and LR for left-right. In addition LC+CR refers to the addition of previously measured LC and CR, this distance should be the same as LR. The maximum difference is  $60\ \mu\text{m}$  meaning that the error of the measurements must be of the order of  $\pm 30\ \mu\text{m}$  on top of the vernier caliper precision of  $20\ \mu\text{m}$ . We take the overall uncertainty as the linear sum of the two values:  $50\ \mu\text{m}$ .

	LC (mm)	CR (mm)	LR (mm)	LC+CR (mm)	(LC+CR) - LR (mm)
IPHC-2021-02	399.66	399.94	799.54	799.60	+0.06
IPHC-2021-03	400.18	399.78	799.96	799.96	0.00
IPHC-2021-04	399.76	400.46	800.24	800.22	-0.02

Table 1: Measurements on plates 02, 03 and 04 between the NCal rods. LC is left-center distance, CR is center-right, LR is left-right. The two last columns are derived from the first columns.

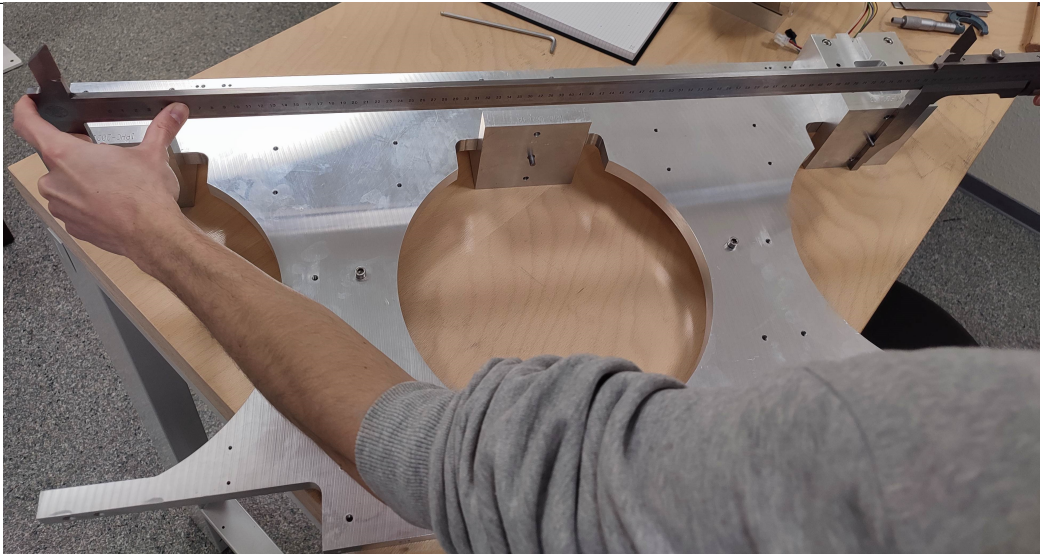

Figure 7: One of the suspended plates being measured using the vernier caliper.

### 2.3 Measurements of the NCal axis offset from the NCal rods

This section concerns the NCal mounted on the NCal rods of the vertical plate. The measurements were done using a vernier caliper "TESA-CAL IP67" with a precision of  $20\ \mu\text{m}$ .

The NCal is placed on a NCal rod on the suspended plate, the offset between the NCal rod and the NCal axis can be determined by measuring distances on both sides of the NCal relative to a fixed point then rotating the NCal and measuring these distances again as shown on fig. 8. The NCal box has two distinct sides, one side is called S (side where there is a "small" metal part visible to hold the axis and the motor) and the other is called B (side where there is a "big" metal part holding the other side of the axis). The "Front" in fig. 8 label refers to the engraved side of the suspended plate.

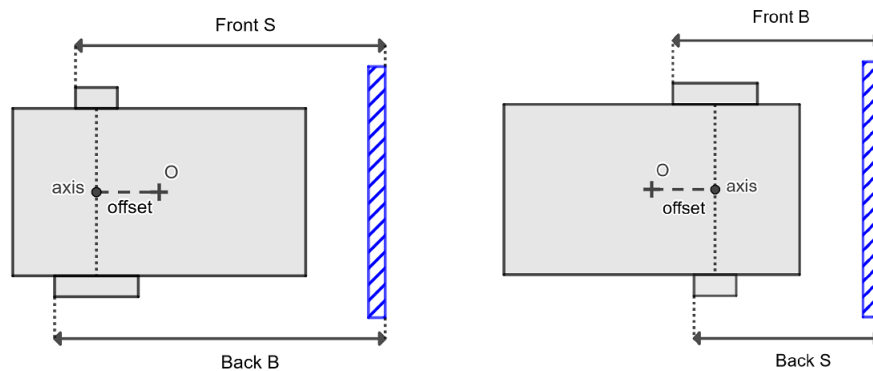

Figure 8: Top view of the method used to determine the offset of the NCal axis relative to the NCal rod labelled as O. The NCal box and the "small" S and "big" B parts are shown in grey. S and B metal parts are used to measure the distance relative to a fixed metal screw shown in blue. Left to right shows the measurements made with the NCal being rotated by  $\pi$  to determine twice the offset. As a convention, the example shown in this diagram gives a negative offset.

This method is performed four times per rotor. We then computed the average offset of each NCal that is reported in table 2. We compute the uncertainty on the measurement by taking the quadratic sum of  $\sigma_{\text{measures}}/\sqrt{4}$  and the vernier caliper uncertainty. The sign convention is taken as in fig. 8.

NCal	Axis offset	Uncertainty
01	+210	30
02	+50	30
03	-300	30
04	+250	40
05	+30	20
06	+70	20
07	-140	70
31	+40	20

Table 2: Axis offsets in  $\mu\text{m}$  of the NCals to their associated NCal rod.

It is important to note that these measurements are valid for a fully assembled NCal (rotor mounted with motor inside the NCal box and screwed), unmounting then mounting the NCal again is very likely to change the measurements.

### 3 Effects of a possible horizontal tilt defect

During their installation, the reference plates were leveled up to 0.4 mrad according to the horizontal plane (this value was determined from the survey reported in logbook entry 53883). When using the template (see fig. 4) to set the axial distance we move by 125 mm along the vertical direction. The possible leveling effect could give an error gives an error of  $125 * 4 \times 10^{-4} = 0.05$  mm on the distance.

The suspended may also not be perfectly levelled. The leveling of this plate was made using the 2.5 mm spacers (see fig. 6) and the position sensors on the reference plate. The sensors could give a planeity of the plate of 0.1 mm over the range of about 800 mm. When going from the plane of the template to the NCal axis, 135 mm above, this could give an error of  $0.1 * 135/800 = 0.017$  mm.

To remain conservative we consider a linear sum of both values giving 0.067 mm as the plane uncertainty on the distance between a NCal and a reference hole.

## 4 Computing the distance from each NCal axis to their reference hole

### 4.1 Layout of the NCal setups

The suspended plates have been placed around the NE mirror (see VIR-1123A-21) as shown in fig. 9.

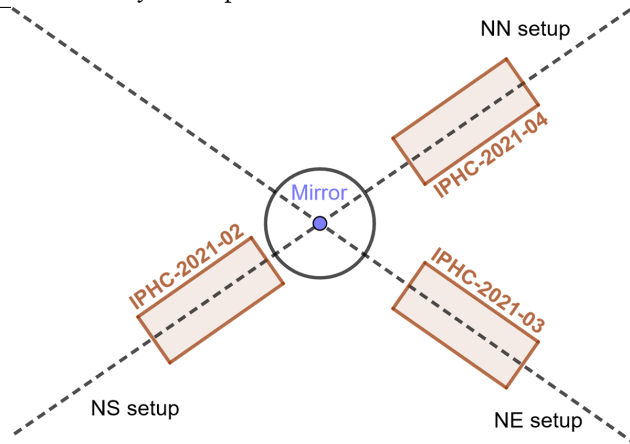

Figure 9: Outline of the three suspended plates around the NE mirror. The label of each plate shows their orientation in respect to their engraved number on the front face.

We will combine the measurements made in this note and determine the distance of each NCal to its associated reference hole considering the current NCal configuration in the NE building (see logbook entries [55624](#), [56139](#) and [56354](#)):

- NE building North Near (NNN): NCal 03 on the L rod
- NE building North Far (NNF) : NCal 02 on the R rod
- NE building East Near (NEN): NCal 04 on the R rod
- NE building East Far (NEF): NCal 07 on the C rod
- NE building South Near (NSN): NCal 31 on the L rod
- NE building South Far (NSF): NCal 05 on the C rod

## 4.2 Values and uncertainties

Considering the orientation of the plates shown in fig. 9 and the measurements made in the previous sections we can draw an outline of the distances to be determined with respect to each suspended plate. The North suspended plate is outlined in fig. 1, East and South plates are outlined in fig. 10.

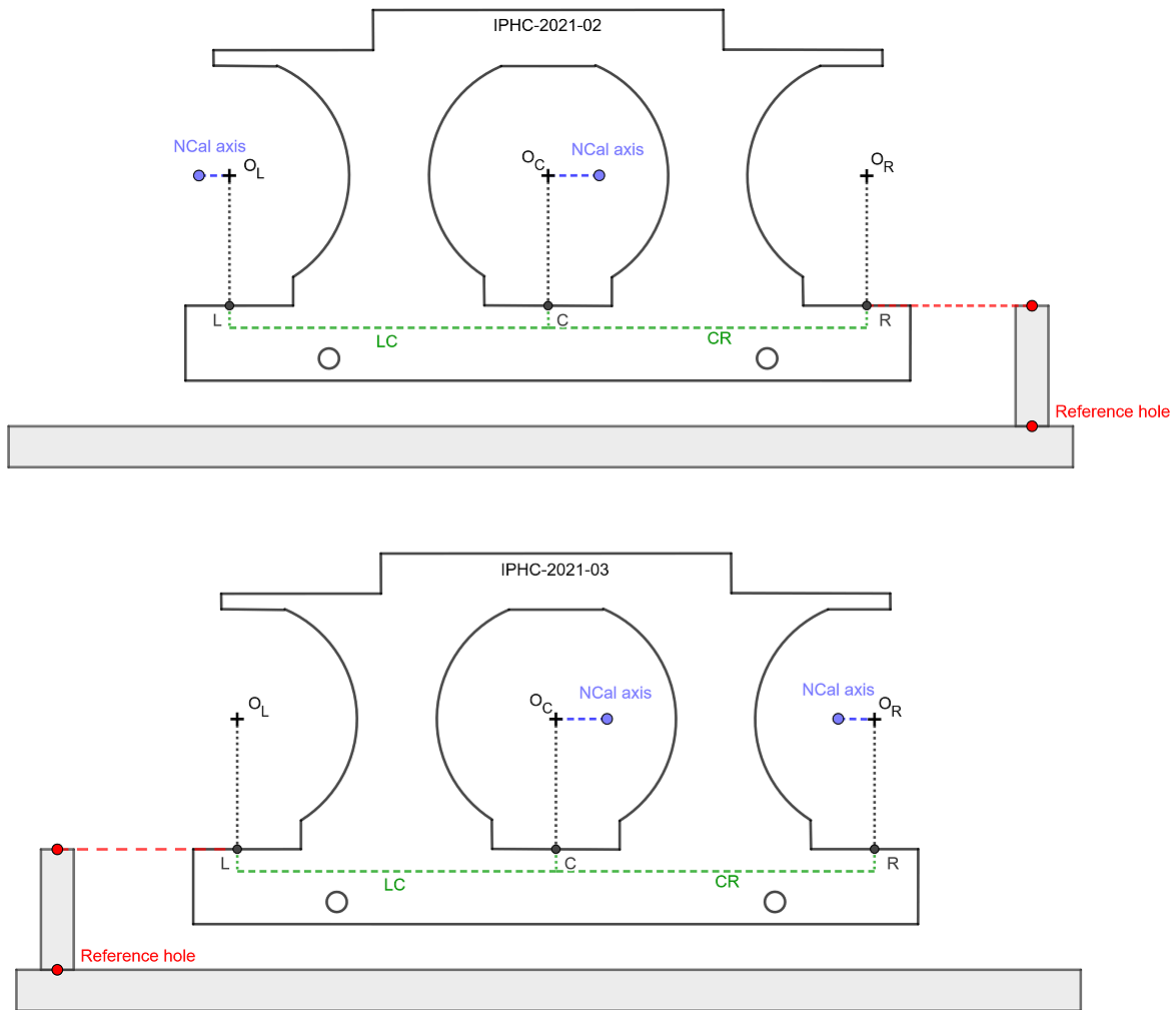

Figure 10: Outline of the front face of the vertical plates suspended on a reference plate, the distances and offsets previously measured are represented as dashed colored lines. On top is shown the outline of the South plate, on the bottom is the East plate. The reference hole to NCal rods distance measured in section 2.1 is shown in red. The distance between NCal rods measured in section 2.2 is shown in green. The NCal axis offsets measured in section 2.3 are shown in blue.

To compute the uncertainty on the distance from a reference hole to a NCal we use a quadratic sum of the uncertainties from the previous sections: the reference hole to NCal rod uncertainty of  $50 \mu\text{m}$ , the uncertainty between NCals rods of  $50 \mu\text{m}$  (depends if the NCal is placed just next to the reference hole or not), the axis offset uncertainty of the considered NCal and we also consider the uncertainty of the position sensors of  $20 \mu\text{m}$  (see VIR-0553A-21). Table 3 shows the computed distances of each NCal to their reference hole and their uncertainty. We note that these distances are absolute and therefore during the computation of the distance of the NCals to the mirror we will have to take into account a sign depending of the suspended plate orientation around the tower.



Setup	NCal	Distance from reference hole	Uncertainty
NN	03 (Near)	899.94	0.08
	02 (Far)	100.05	0.06
NE	04 (Near)	900.21	0.08
	07 (Far)	500.04	0.10
NS	31 (Near)	899.94	0.08
	05 (Far)	499.97	0.08

Table 3: Absolute distances in mm of each NCal to its reference hole and their associated uncertainty.

The distance between two NCals on the same setup is shown in table 4. The uncertainty on this distance is the quadratic sum of the uncertainty between two NCal rods of 50  $\mu\text{m}$  and the two maximum NCals axis offsets of 70  $\mu\text{m}$  and 40  $\mu\text{m}$  to remain conservating when swapping NCals between setups.

Setup	Distance	Uncertainty
NN	799.89	0.09
NE	400.17	
NS	399.97	

Table 4: Absolute distances in mm between NCals on a same setup and their associated uncertainty.

We can combine the results of table 3 with table 8 of [VIR-0343A-22](#) to compute the uncertainty on the distance between two NCals along the North to South axis as shown in table 5. The overall uncertainty is computed using a quadratic sum of the uncertainties from both tables and the tilt uncertainty given in section 3. We will take the maximum of 0.98 mm as the uncertainty between two NCals along the North to South axis to remain conservative.

NCals	Distance	Uncertainty
NNN-NSN	2998.34	0.97
NNF-NSF	4198.20	0.93
NNN-NSF	3398.31	0.92
NNF-NSN	3798.23	0.98

Table 5: Absolute distances in mm between NCals along the North to South axis and their associated uncertainty.



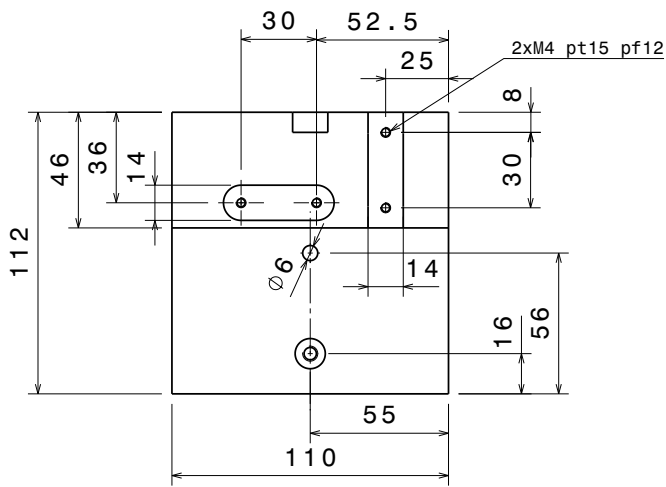

Vue de dessous  
Echelle : 1:2

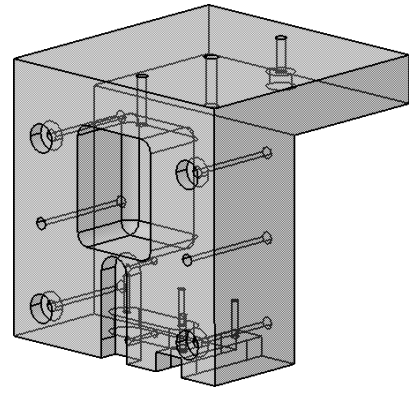

Vue isométrique  
Echelle : 1:2

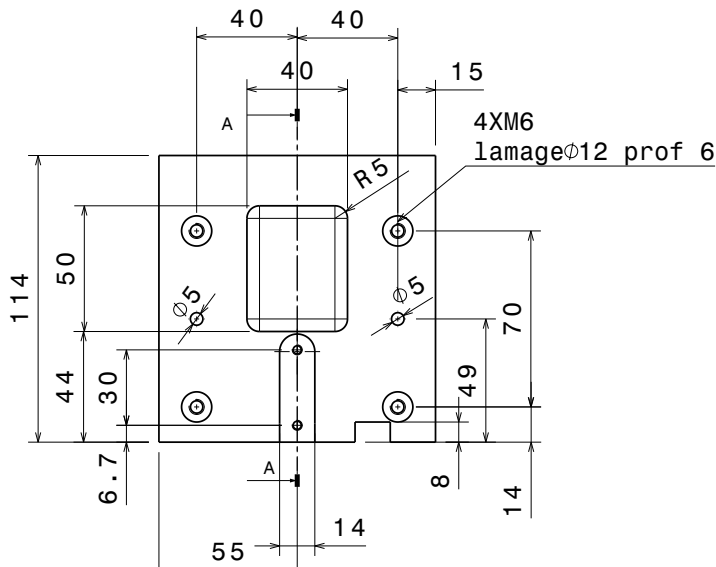

Vue de face  
Echelle : 1:2

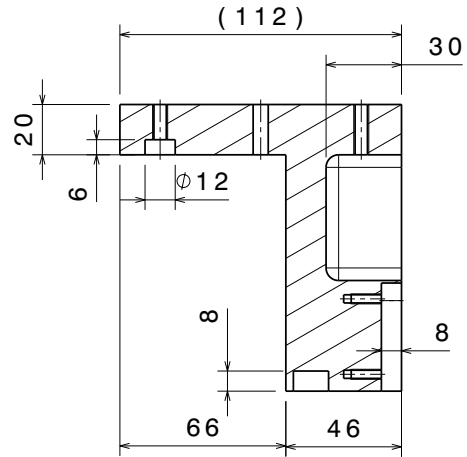

Coupe A-A  
Echelle : 1:2

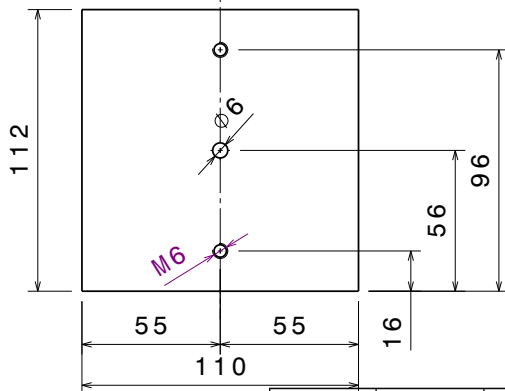

Vue de dessus  
Echelle : 1:2

N°	9	Al		1,7/pièce	
Qté		Matière	Traitement de surface	Masse Kgs.	Dessin d'ensemble
Rug. gén. : Ra = 1,6		Tol. gén. : ISO 2768 mK	Chanfreins : 0,2 à 45°	Projet :	VIRGO
<b>PIECE L Ncal</b>					
Dessiné par :		Vérifié par :		A3	Numéro
V. Zeter		26/06/2021			Echelle 1:2



VIRGO\_Vu Laterale Ncal Nord  
04/11/2021

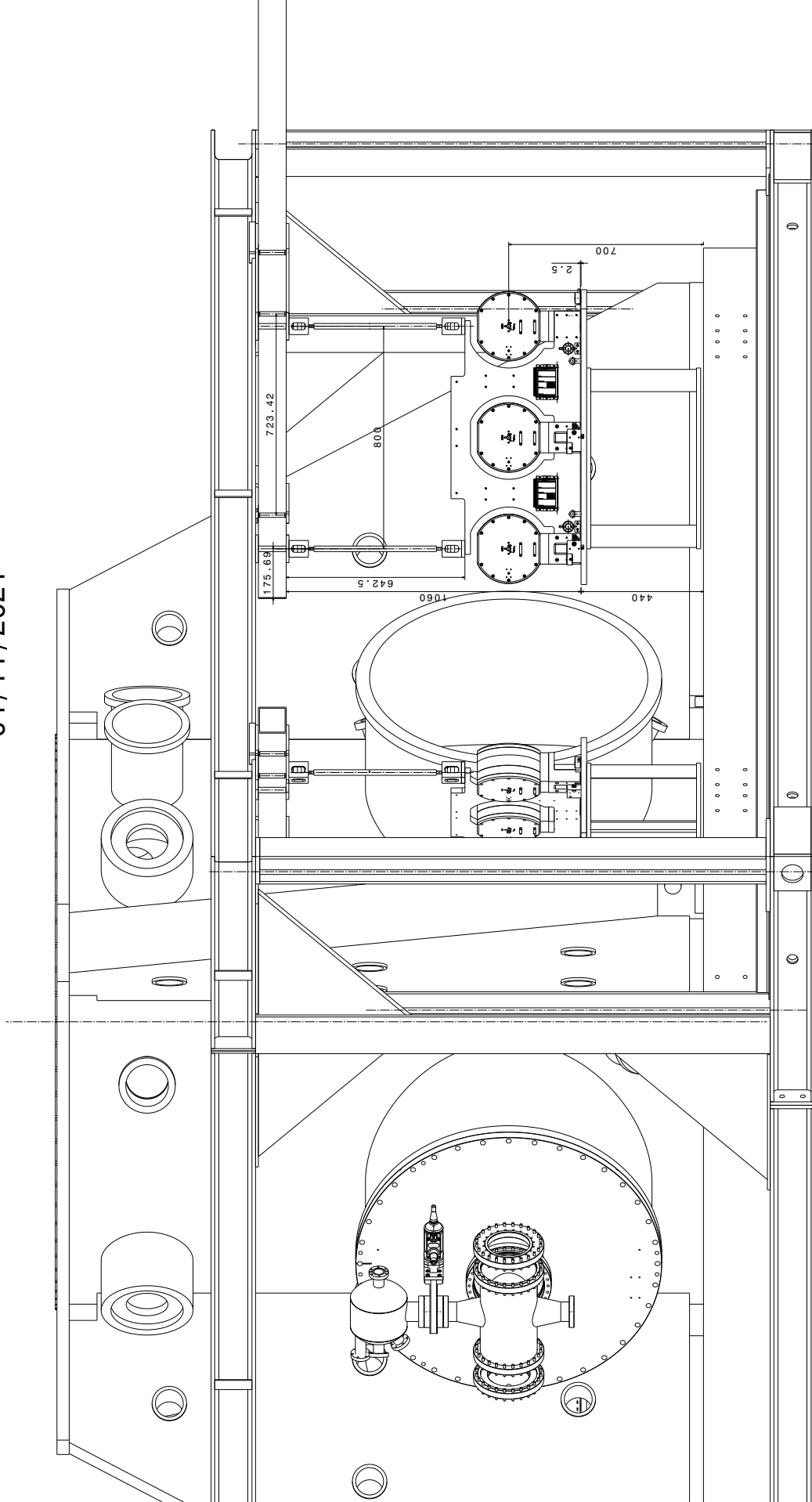

Vue de face  
Echelle : 1:5