

Advanced Virgo Commissioning



Gabriele Vajente

LSC-Virgo meeting – Rome

September 11th 2012

Outline of the talk

■ What's inside

- Expected tough points in AdV commissioning
- Staging of installations to speed up partial commissioning
- Early ITF configurations to stage commissioning activities
- What configuration for early science runs?
- Some thoughts on the commissioning organization

■ What's not inside

- A timeline for the commissioning of AdV
- Evolution of the sensitivity in the coming years

Disclaimer:

Most of the ideas shown in this talk have not been widely discussed within the Virgo collaboration yet

Take this talk as a trigger to start *working* on the AdV commissioning organization

WHAT DIFFICULTIES DO WE EXPECT IN ADV COMMISSIONING?

Sideband aberrations – problem

- **Mirror cold defects** and **thermal effects** will induce large aberrations in the RF sideband fields
 - In AdV this is very relevant due to **marginally stable recycling cavities** (AdV will be more degenerate than Virgo/Virgo+)
- Both **axisymmetric** and **non-axisymmetric** contributions are relevant
- This put since the beginning (and even with low input power) the **TCS in the front line**

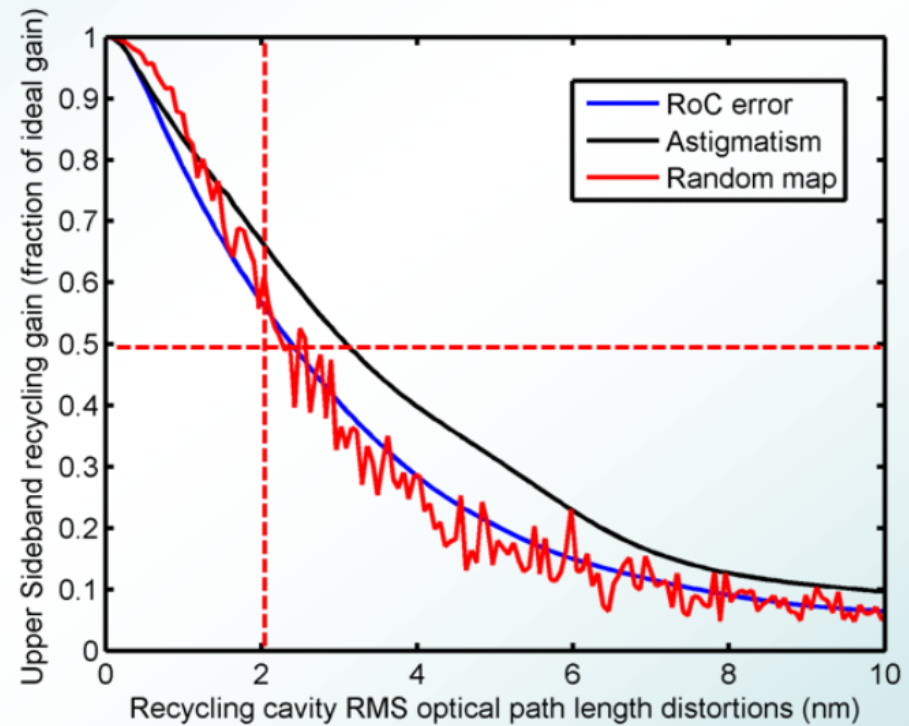

**Requirement: SB gain
at 50%: 2 nm RMS**

**Total wave-front distortion
(in cold state) in recycling
cavity will be 10 nm RMS**

Sideband aberrations - strategy

- We foresee an **additional, high frequency, modulation** that will be less sensitive to defects: we will be able to control the ITF even in presence of large defects
- TCS is being carefully designed, based on Virgo+ experience
 - **Phase cameras** to sense the fields (proved to be very useful in Virgo+)
 - Hartmann sensors to measure and actively cancel the thermal lensing
 - Double axicon CO2 projector and scanning system for complete correction on input mirror compensation plates

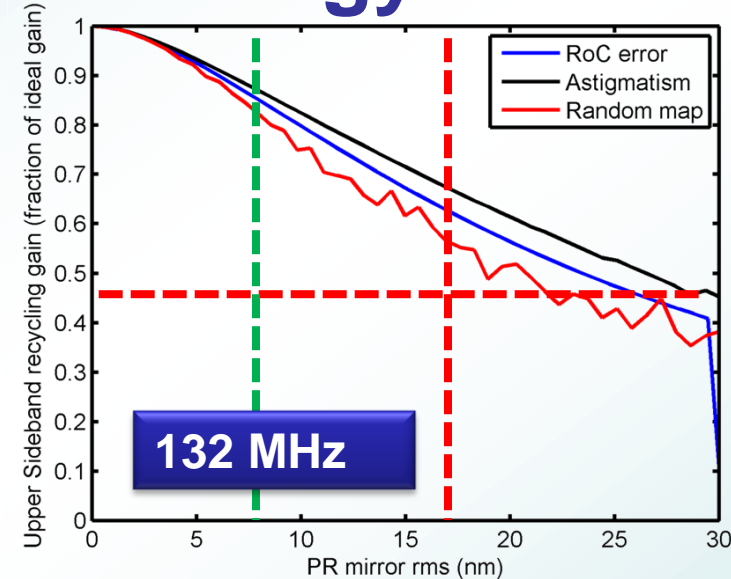

- **Simulation studies** are being carried out to understand how to best use ITF signals (and images) to characterize sideband aberrations

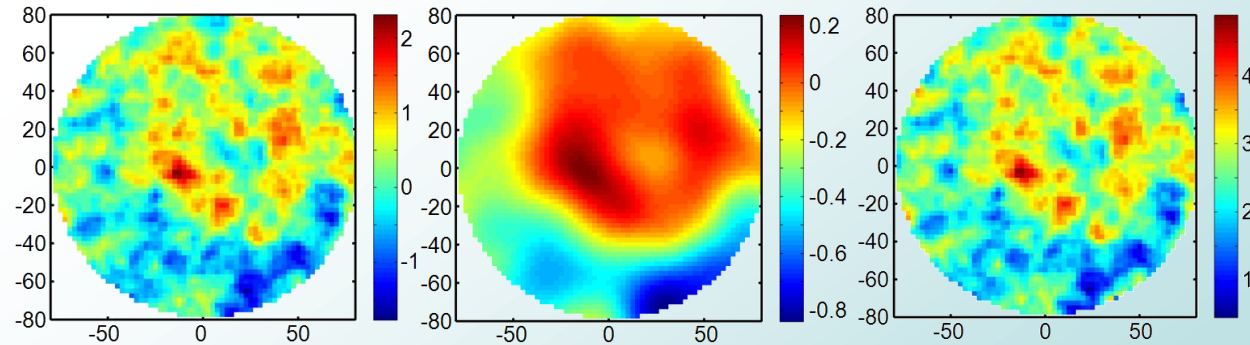
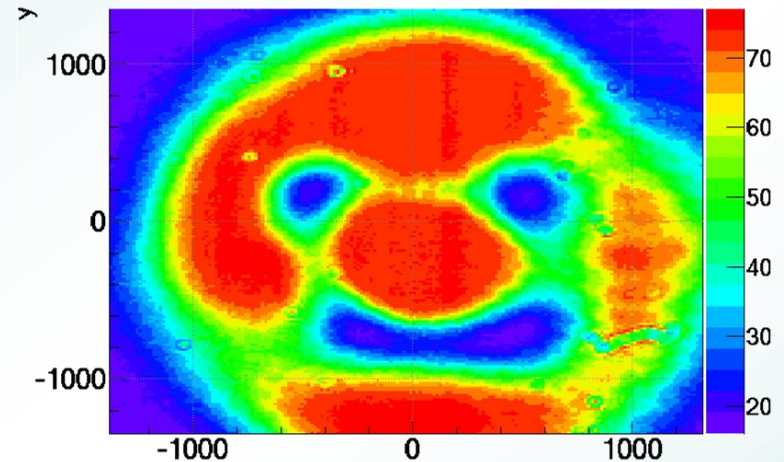

Figure 6.47: FOG simulation. Left: common aberration in recycling cavity (color scale in nm). Middle: phase difference between upper sideband and carrier (color scale in rad). Right: Resulting aberration map after filtering phase difference map (color scale in nm). Horizontal and vertical scales in mm.

Carrier defects – problem

- In Virgo+ we had many troubles due to **arm cavity asymmetries**:
 - **Radius of Curvature** asymmetries generating high order modes reaching the dark fringe
 - High **losses asymmetry** spoiling the contrast defect
 - Finesse asymmetry
- Even in Advanced Virgo, coupling of laser frequency and power noises put **stringent requirements on losses and finesse asymmetries**
- High order modes at dark fringe create problems to **alignment signals**
- In AdV the modes of 8th order are close to resonance



Dark fringe beam with high order modes

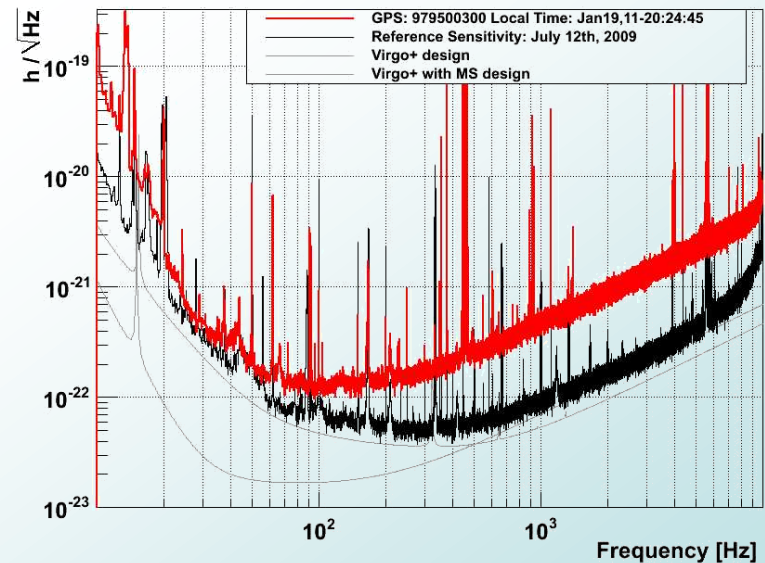

Some early Virgo+ sensitivity limited by frequency noise due to too large losses asymmetries

Carrier defects - strategy

- Obvious thing: **mirror surfaces** must be as good as possible (coating is playing an important role)
- **Ring heaters** to fine tune RoCs (and possibly improve losses)
- We can **optimize the contrast defect** by applying a RoC asymmetry (done in Virgo+)
- Input mirror have parallel surface to tune cavity finesse using etalon effect
- Do we need some way to fine tune mirror shapes during operations?

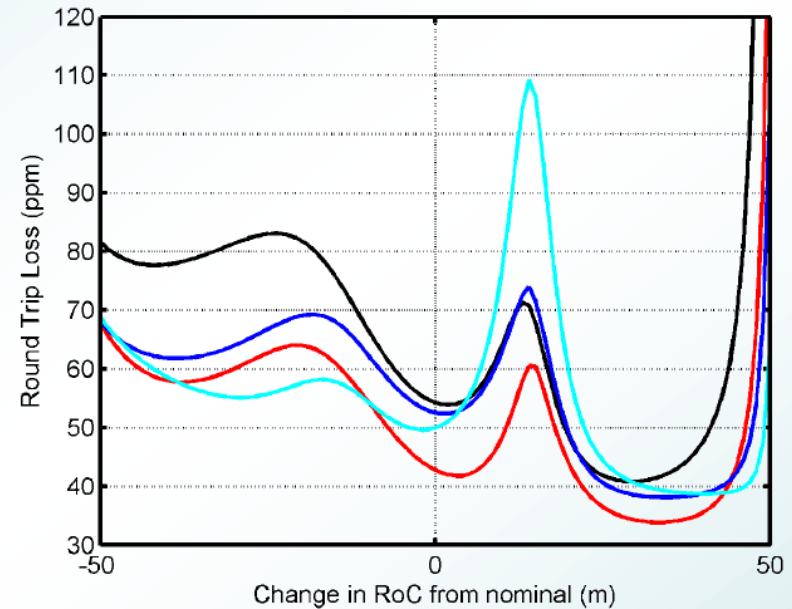

Round trip losses in AdV as a function of the RoC deviation from nominal value

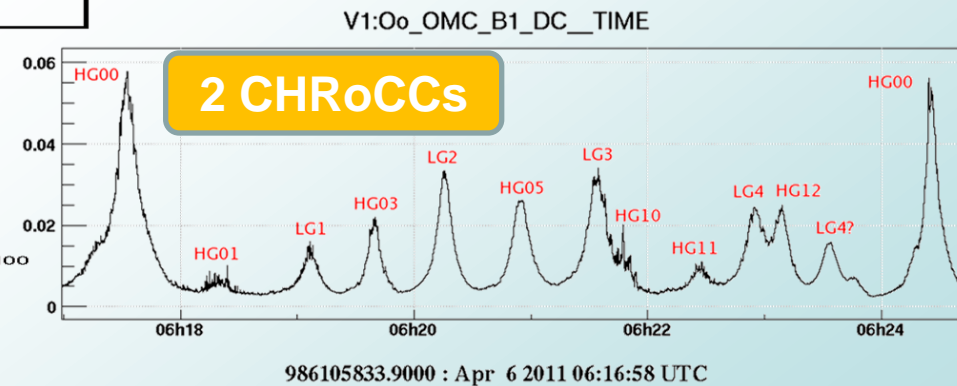
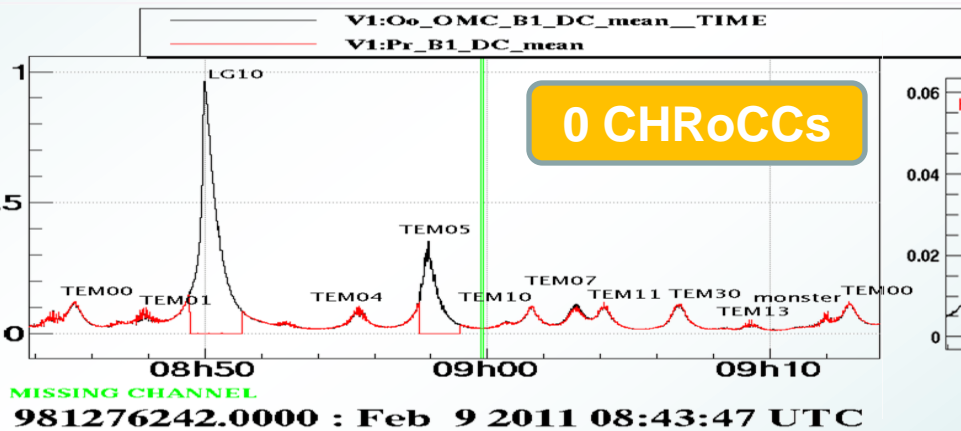

Dark fringe beam content analyzed doing a scan of the OMC

Scattered light - problem

- All first generation detectors suffered from **scattered light**
- We learnt a lot during Virgo/Virgo+ commissioning
- Beams reflected by **secondary surfaces of core optics**
- Light scattered and reflected by **auxiliary optics** (in particular anti-symmetric port high order modes)
- Light scattered by out-of-vacuum, not isolated objects

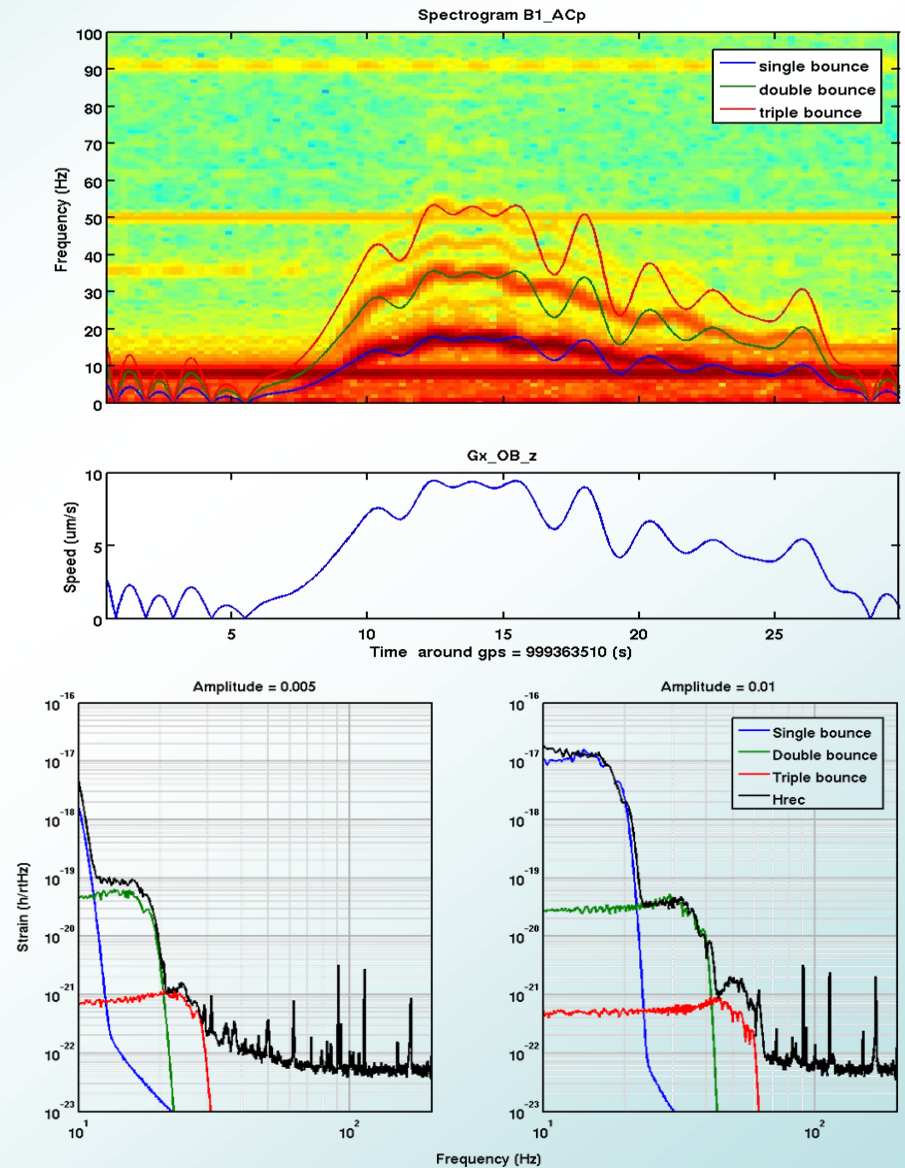

Scattered light - strategy

- All experience went into the AdV design (lot of simulations)
 - **Suspended baffles** integrated in payloads around each core optic
 - Careful **evaluation of scattered light** from input and output telescopes (need to control benches w.r.t. ITF)
 - Critical photodiodes are in vacuum and seismically isolated
- However, **scattered light is the most tricky noise source**
- We must be **ready for quick actions** (like changing part of telescope optics if in doubt)

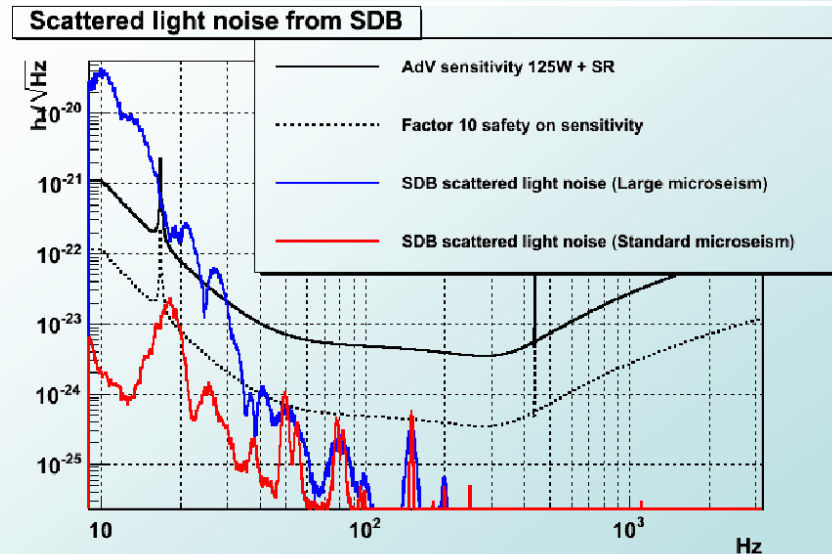
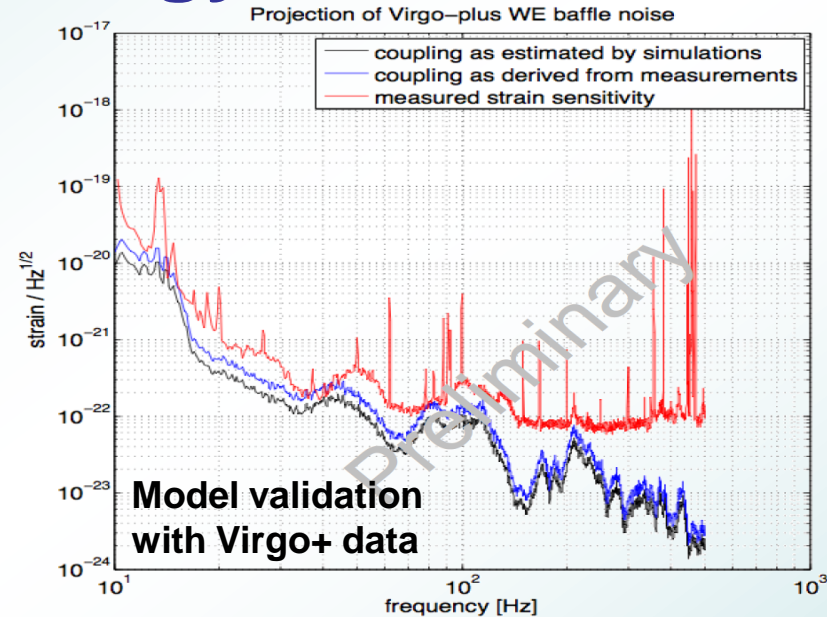

- **New technology** for us
 - New electronic for photodiode readout
 - Photodiode under vacuum
 - Power stabilization
- **OMC has very stringent requirements** for sidebands and HOMs filtering
 - It was chosen to have two OMCs in series
 - Difficult from the point of view of relative alignment, matching, losses, scattered light
 - Allows to maintain Virgo-like technology

Frequency [MHz]	PR 25 W	SR 25 W	SR 125 W
6	1/120	1/7	1/36
56	1/1700	1/460	1/2300

Sideband filtering requirements

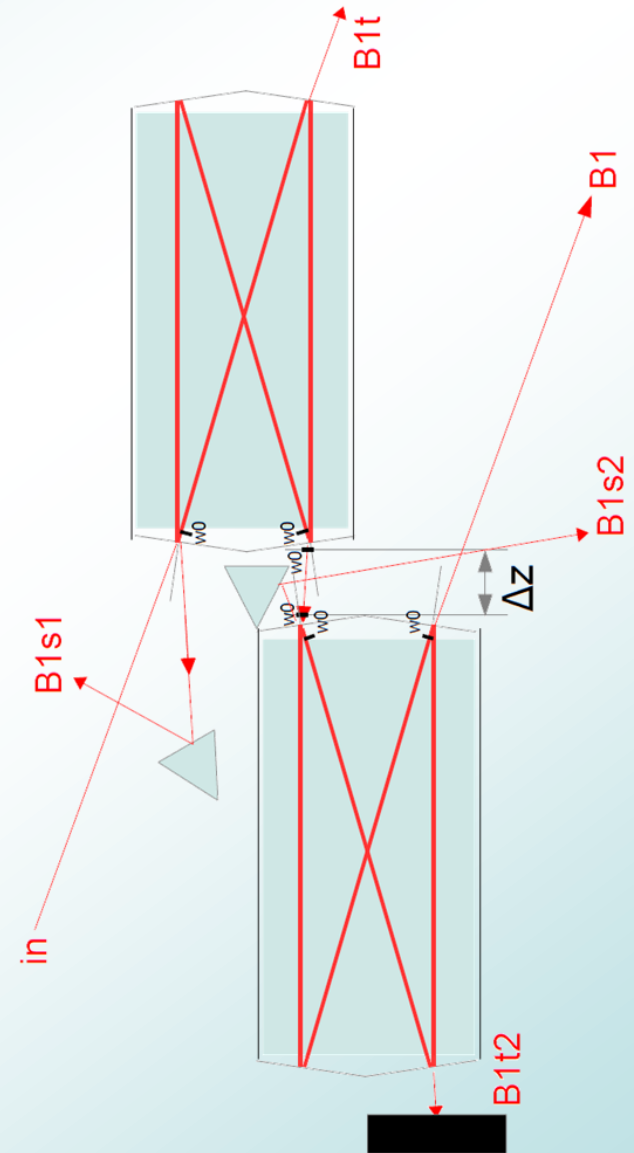

Signal recycling

- Design of **steady state control configuration** of detuned SRC completed
 - Broad-band configuration is being studied, hear more later
- Started working on lock acquisition, so far **no clear if Virgo-like variable finesse is doable**

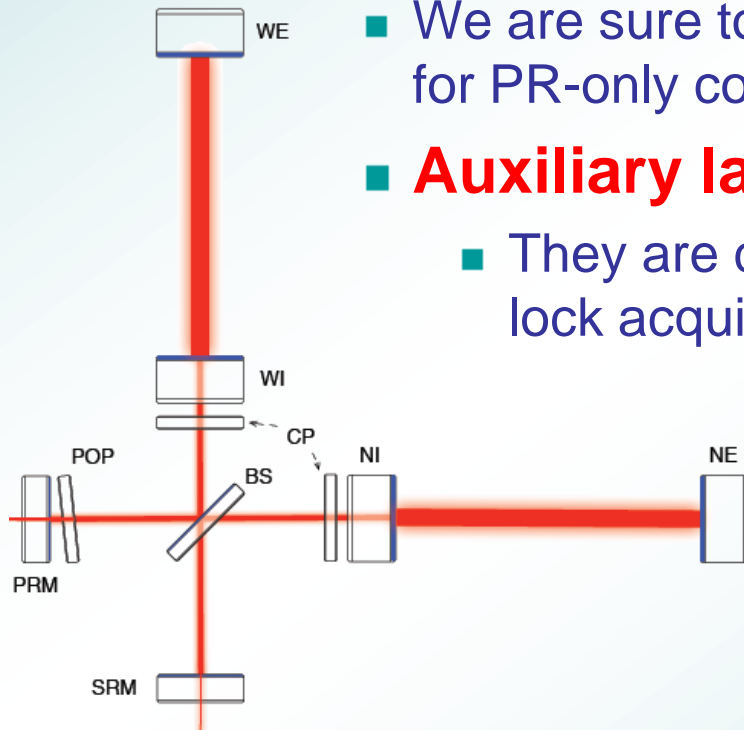

- We are sure to be able to use Virgo-like lock acquisition for PR-only configuration
- **Auxiliary lasers** are in the baseline design
 - They are considered as an important tool for the lock acquisition of the dual recycled interferometer

HOW CAN WE STAGE THE INSTALLATIONS TO SPEED UP COMMISSIONING?

Early subsystems

- **Suspensions and payloads**
 - **No big differences in suspensions** w.r.t. Virgo+ (some retuning to allow different weight of the payload, some additional filters added to short superattenuators)
 - **Payloads will be new**, as well as the interface between payload and suspension: some re-commissioning of the controls will be needed.
- **Injection system** will be the first subsystem online
 - There will be plenty of commissioning to do:
 - Frequency stabilization on IMC
 - IMC control (local and global)
 - RFC lock
 - Input power control system and power stabilization
 - There will be some time before laser is really needed, good to (re) train commissioning group (hear more later)
- We will likely start with the **Virgo+ laser amplifiers** (60W available before IMC)

Intermediate configurations

- Organize installation to have **first one full arm**
 - Need everything on the arm: test masses, suspensions, vacuum links, cryotrap, end detection benches (possible also to have them simply sitting on ground, not yet seismically isolated)
 - But **also need PR mirror** (is part of the input telescope) and **BS mirror** (beam shift)
 - We might work without detection benches at anti-symmetric port
- We will be able to
 - Validate suspensions, payloads and local controls
 - Learn how to lock a 450 finesse cavity
 - **Characterize mirror radii of curvature, losses, finesse**, etc...
 - Use it **to test auxiliary sensors** (phase camera, Hartmann, etc...) and **actuators** (ring heaters, etalon control, etc...)
 - Characterize **input beam** control
- Lock the second arm quickly

Power recycled configuration

- Second step is to commission **power recycled interferometer**
 - We know how to lock and control it
- To make PR configuration work we will have to
 - Characterize and correct sideband aberrations due to **mirror defects** (start at low input power)
 - Characterize and compensate **thermal effects** (present even when at low/moderate input power)
 - Make **DC readout** and **OMCs** work
 - Characterize and possibly correct or compensate **losses asymmetries**, **high order modes** at dark port, etc...

AR-coated SR mirror is needed, being part of the output matching telescope

Working with PR configuration is very useful: it is a simpler configuration (w.r.t. dual recycled) but with most of the main problems we are expecting!

Power recycling potentiality

- PR configuration at 25W input power could **reach good low frequency sensitivity** and 106 Mpc BNS / 970 Mpc BBH
- Enough sensitivity to see and track down scattered light
- Enough sensitivity for **first science runs**
- Remove all control issues related to SR cavity

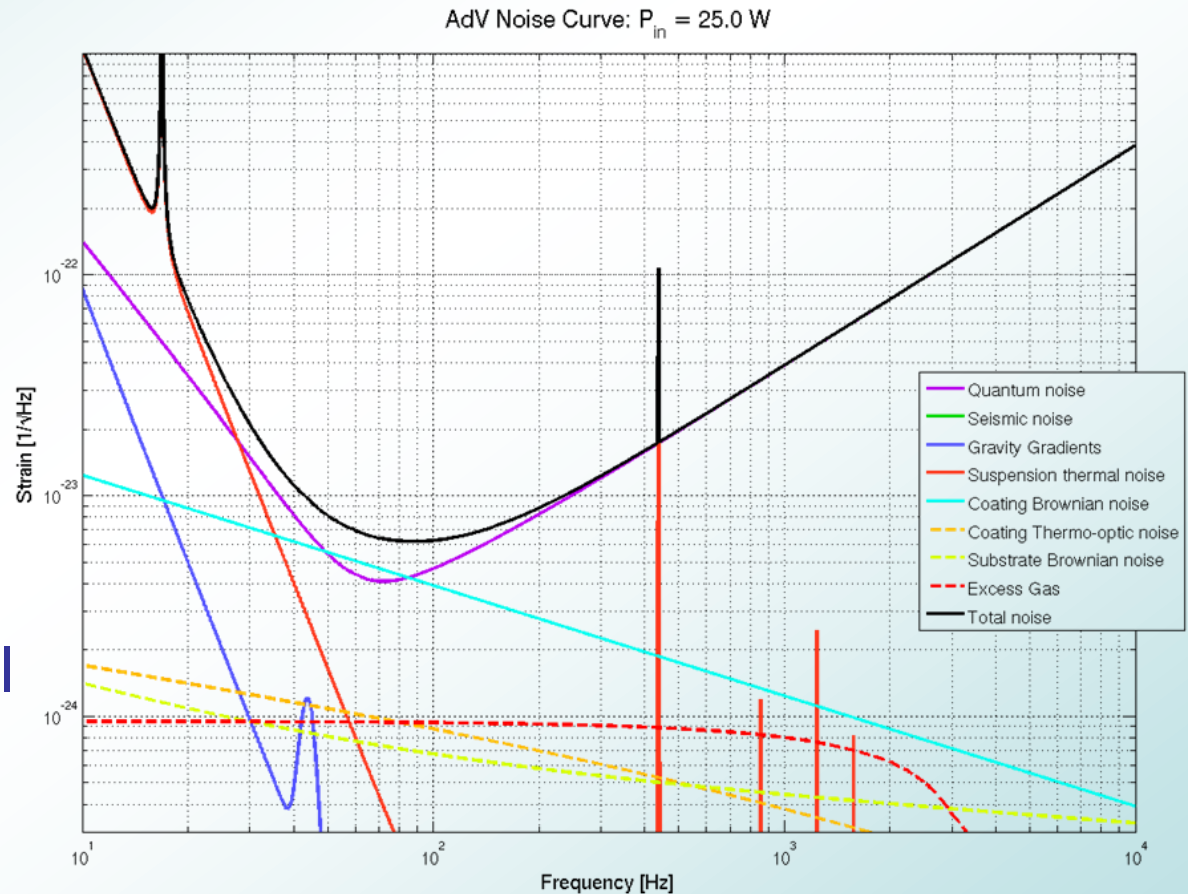

Power recycling potentiality

- Increasing the power in PR configuration helps a bit for BNS, but not for BBH
- Not really worth to go above 50 W input power
 - We don't need the 200W amplifier since the beginning

BNS range [Mpc]

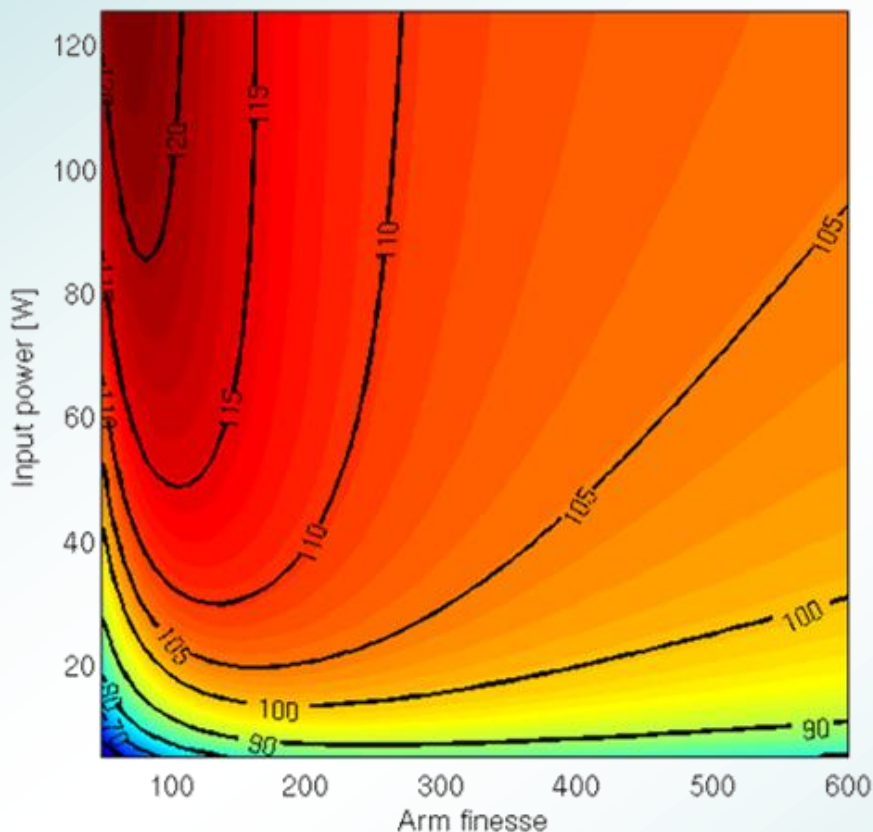

BBH range [Mpc]

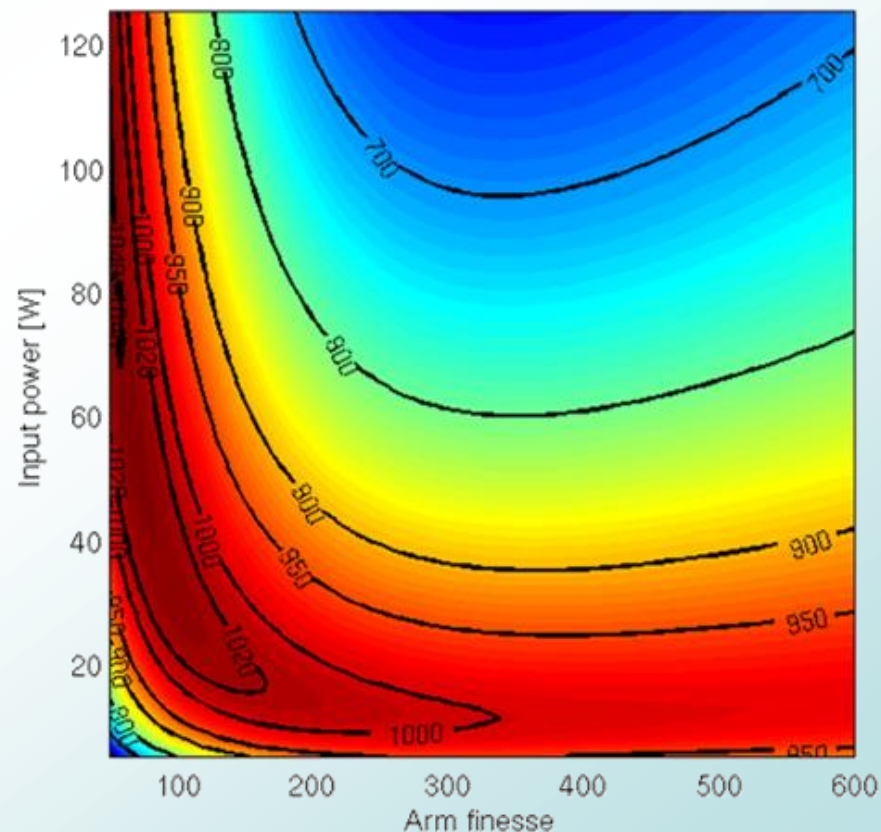

Configurations comparison

BNS	25 W	50 W	125 W
Power recycled	106	110	112
Broad band	106	121	133
Detuned NS optim	126		142

BBH	25 W	50 W	125 W
Power recycled	974	867	669
Broad band	1005	1050	986
Detuned NS optim	1217		1120

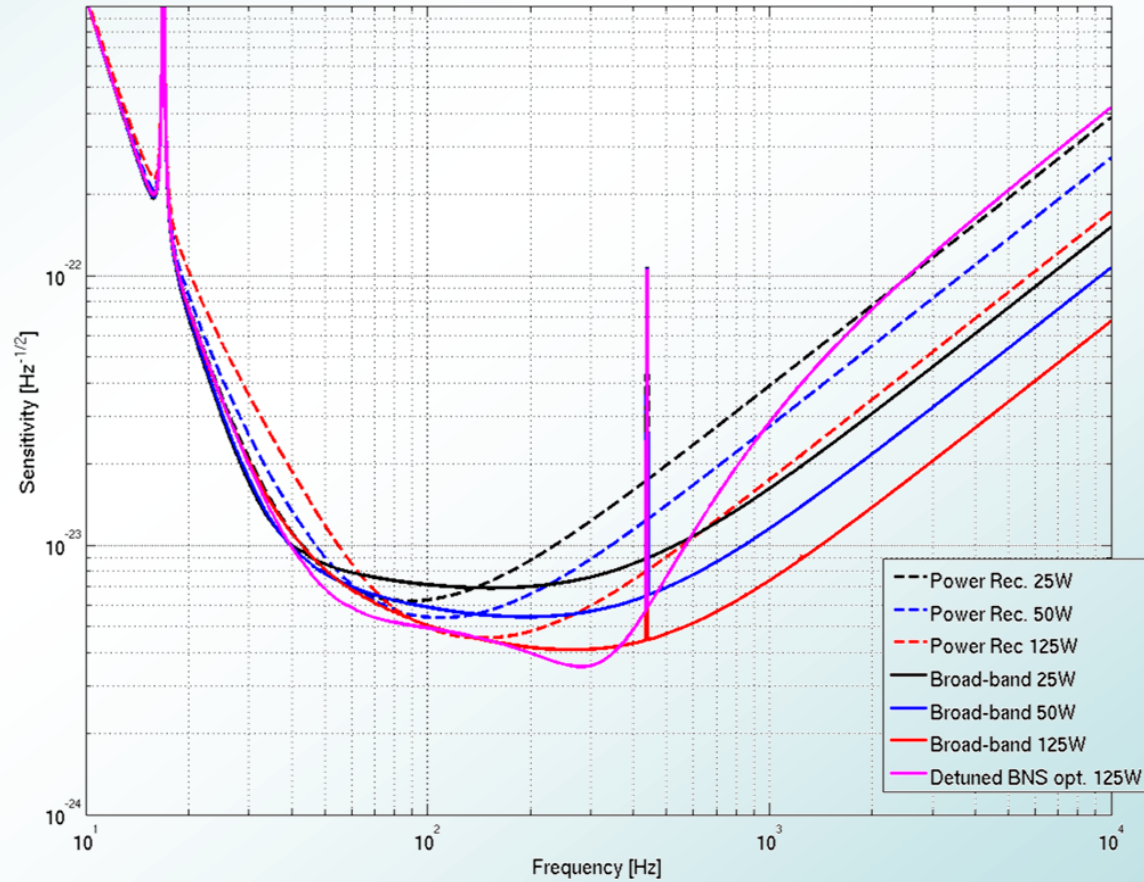

Moving to dual recycled

- It makes sense only **after the main problems have been tackled** in PR configuration
 - Sideband aberrations, arm cavity asymmetries, scattered light, DC-readout, OMC, etc...
 - If these things are working in PR configuration, they will be (almost) identically working in dual recycled one
- We might foresee one or two stops, after first science run(s) for the upgrade to dual recycling
 - Install SR mirror and laser power amplifier
 - Install SR mirror and only later laser power amplifier
- What configuration for signal recycling?

Broad-band optimization

- Best choice in broad-band configuration is SR transmission 45%
- Could achieve 132 Mpc BNS and 1050 Mpc BBH
- If SR reflectivity is lower, control should be easier (not studied in detail yet)

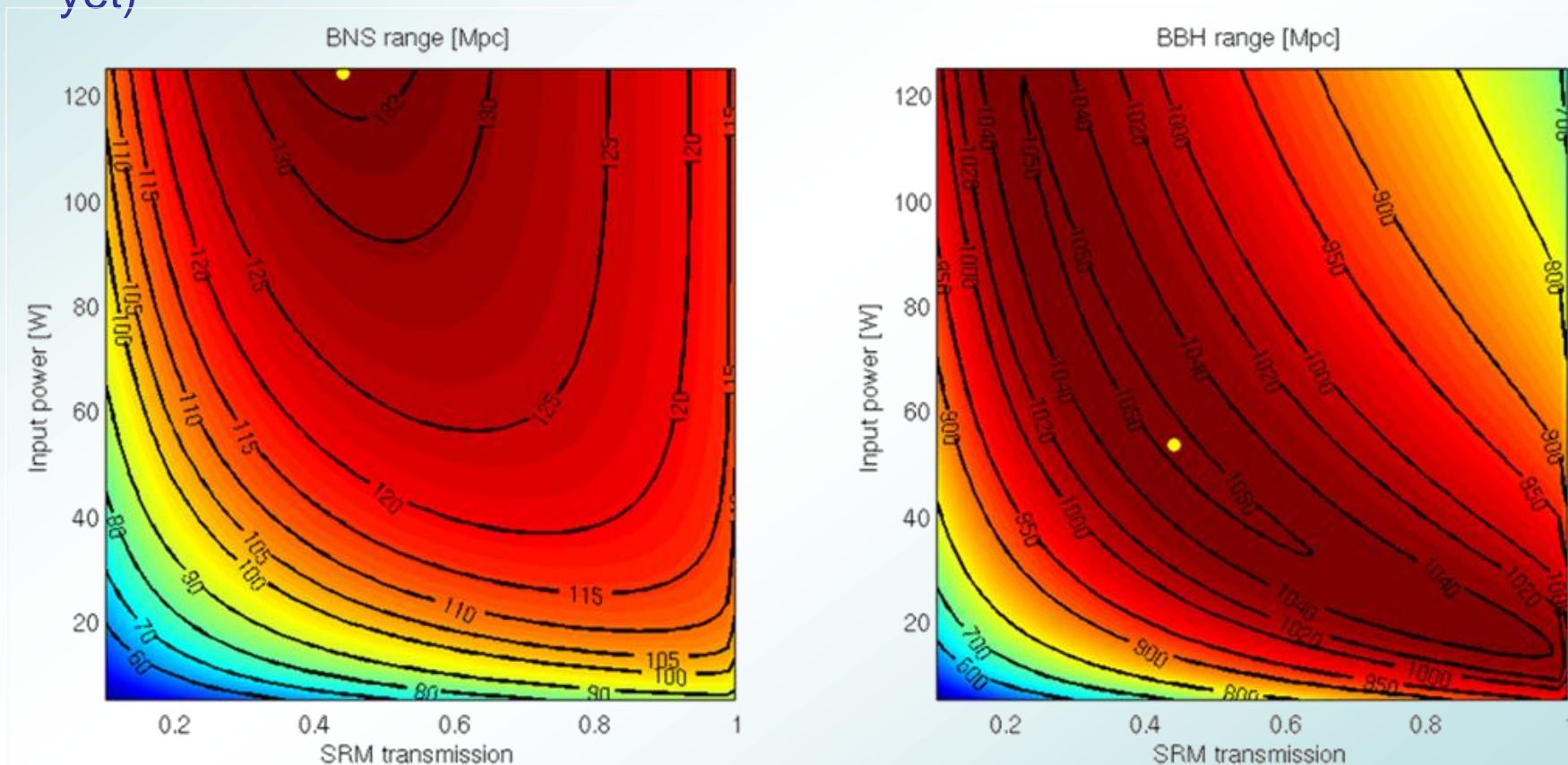

SOME THOUGHTS ON THE COMMISSIONING ORGANIZATION

What do we need?

- We must **be fast and efficient** when AdV will be completely installed
 - Otherwise AdV commissioning will add delay
- Therefore, when construction will end **we need a core group ready to work and already having some experience**
 - Keep **involved and motivated** those people that commissioned Virgo/Virgo+
 - **Involve new people** (PhD, Post-docs) **and train them** (old commissioners might not be able to devote 100% to commissioning any more)
 - **Learning curve is steep** (one year to understand what's happening around you...)
 - People should spend time at the site



How to get it?

- **Now** is the right moment to start:
 - Ensure experienced people are present and motivated
 - Commit new people (**Ph.D. students, post-doc**) to commissioning
 - **Start right now** with a partial (50%) commitment, to be increased when needed
- Must **profit of all subsystems that will be ready early**
 - Involve the group in commissioning of, for example, injection system
 - Might slow down subsystem commissioning, but this is not a problem if not in the critical path
- Use all **prototypes** to train new people
 - Will provide fresh manpower to labs running the prototypes, speeding up their work
 - Will allow some experimental work before AdV is ready
- Reinforce **Virgo-LIGO-GEO collaboration**
 - Informal meetings and people exchange will be good for everyone

CONCLUSIONS

Conclusions

- Commissioning of Advanced Virgo will be a difficult job
 - We foresaw at design all the solutions we could devise for all known tough points
- Proper **staging of the installations**
 - To be able to commission subsystems that are ready early
 - It will be a good occasion to train new people that must be a significant part of the (to be formed) commissioning group
- **Power recycled configuration** will be very useful
 - We might spend a significant amount of time with it
 - It is a simple (from control point of view) configuration where **many of the main difficulties are already there**
 - It has a **non negligible science potential**
- Dual recycled will come later
 - We are considering to change over to broad band (at least as a first configuration)