

CNRS
Centre National de la Recherche Scientifique

INFN
Istituto Nazionale di Fisica Nucleare



Optocad layouts of the suspended pick-off benches of AdV: SNEB/SWEB and SPRB

L. Rolland, R. Bonnand, R. Gouaty, F. Marion, B. Mours

VIR-0254A-13

June 6, 2013

VIRGO * A joint CNRS-INFN Project
Project office: Traversa H di via Macerata - I-56021 S. Stefano a Macerata, Cascina (PI)
Secretariat: Telephone (39) 50 752 521 – Fax (39) 50 752 550 – e-mail virgo@pisa.infn.it

Contents

1	Introduction	3
2	Preliminary remarks	3
3	Suspended end benches: SNEB and SWEB	4
4	Suspended PR bench: SPRB	7
4.1	SPRB main pick-off beam: B4	7
4.2	SPRB secondary pick-off beam: B4p	10
4.3	SPRB secondary beams from the CP: B6, B6p, B9 and B9p	12
4.3.1	Beam B9 on SPRB	12
4.3.2	Beam B9p on SPRB	12
4.3.3	Beam B6 and B6p on SPRB	14
4.3.4	Beams B9 and B9p on SPRB, with a wedge on the CP	14
4.3.5	Realistic visualizations of all the beams on L2 and on the diaphragm	16
A	SNEB/SWEB telescope parameters	20
B	SPRB telescope parameters	22

1 Introduction

The optical layouts of the suspended benches used to measure the beams transmitted by the end mirrors and reflected on the PR pick-off plate are given in this note. The suspended benches are squares of 1.3 m side that will be suspended to a multi-SAS attenuator inside a so-called minitower (see section 12.4 of [1]). Two minitowers have already been produced [2]: they will be installed in the end buildings with the SNEB and SWEB benches: for these two minitowers, the viewport positions are well defined. The other minitowers are not yet completely designed. In particular, the viewport positions can still be adapted.

Preliminary layouts had been done for the AdV Technical Design Report [1] (sections 7.8.6 and 7.9.3 of [1]) beginning of 2012. The layouts presented in this note have been computed with Optocad¹. For the two layouts given in the different sections, some specific points that are not completely defined are highlighted.

2 Preliminary remarks

Some general comments valid for all the layouts can first be given:

- The precise positions of the minitowers are not completely defined.
- The coordinates of the benches shown in the figures are the coordinates in the *optical reference system* [1] defined as follows: the origin corresponds to the center of the BS hole in the pavement of the central building, the x-axis is along the west arm oriented towards east, the y-axis is oriented along the north arm oriented towards north.
- The aperture radius of the first optics (doublet) is 112 mm, which is larger than the typical height, 100 mm, of the propagation plane of the beams on the benches. As a consequence, the benches will be lowered by 2 cm such that the incoming beam has a height of 120 mm above the bench surface and enters the doublet at its center. Then, the beam height will be reduced from 120 mm to 100 mm between the telescope folding mirrors M1 and M2.
- The sizes of the photodiode (blue) and camera (yellow) air-boxes are the ones from the prototypes being tested at LAPP [3].
- The size of the air-boxes (green) to host the quadrant photodiodes used in DC is the one from the prototype being tested at Nikhef [3]. However, the size of the air-boxes to host the quadrants read in AC are expected to be the same.
- The size of the galvanometers (gray) is the one from the prototype being tested at Nikhef.

¹ Optocad version 093g. The layouts configuration files are archived in CVS/SVN in the package Optocad-Configs and have been tagged as v0r13 on June 6th 2013

- Except for the telescopes, the size of the optics has been chosen to be 2" in general to ease the alignment².
- The name given to the mirror reflect if they are motorized or not. They are called "M" when not motorized, and "Mmot" when motorized. There is one motorized mirror in front of each sensor (photodiodes, quadrants, cameras).
- The cables to bring the power to the bench electronics and for the I/O signals might arrive around the central suspension cable³, within a radius of ~ 10 cm. This has to be studied in more details since the current layouts have beams closer at distances lower than 10 cm from the bench center.

3 Suspended end benches: SNEB and SWEB

The suspended end benches in NE and WE end buidlings are called SNEB and SWEB. Both benches will have the same optical layout. The layout designed for SNEB is shown in figure 1.

Some general comments can be given first:

- The longitudinal positions of the SNEB and SWEB minitowers are not completely defined. The rough positions are given as the distance from the center of the end suspension to the center of the minitower: 8.356 m for NE and 7.730 m for WE. It has been checked that the layout drawn for NE is not modified if the distance is modified.
- The lateral position of the minitowers is fixed in order to have the viewport centered on the input beam: $x=-0.110$ m for SNEB, $y=-0.110$ m for SWEB.
- Some space has been kept for the auxiliary beam of ISC (CALVA), but the detailed design is not yet available.
- There is no Hartmann beam planned on this bench anymore.
- Some additionnal optics will be needed to design an optical lever between the bench and the end mirror. Some preliminary layout has been drawn to remind it, but the design is not yet ready.

The input beam, coming from the ITF, has a waist of 6.7 mm located ~ 1150 m before entering the minitower. Its size at the level of the first face of the double (lens L1a) is 58.8 mm. In the final AdV configuration, the power inside the arm cavity is expected to reach 650 kW (see[1], p. 17). and the transmittivity of the end mirrors is expected to be of the order of 1 ppm: in this case, the power of the beam incoming on SNEB should be of the order of 650 mW in

² 1" (inch) = 2.54 cm

³ From discussions at the DBE-DET meeting at Nikhef on June 3rd 2013.

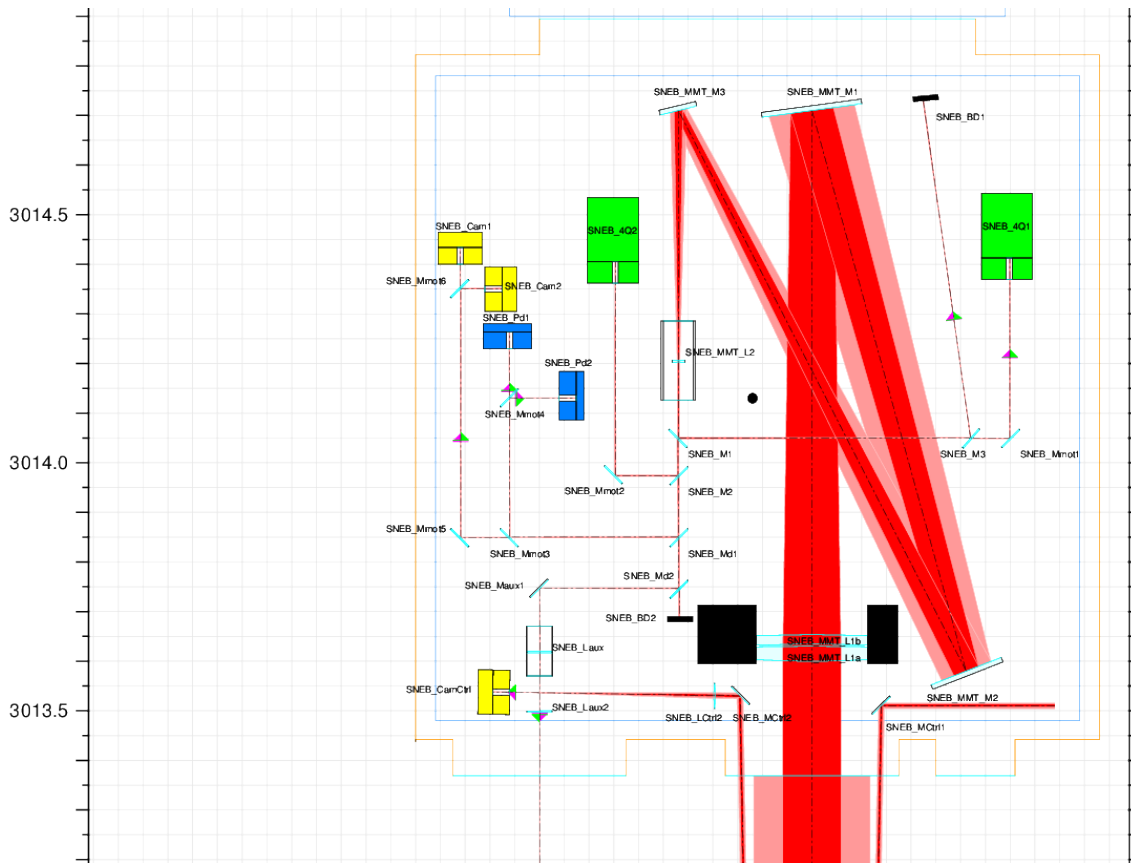

Figure 1: Optocad layout of SNEB to extract the pick-off beam B7. The layout of the SWEB bench, to extract the beam B8, is the same. The dark blue square indicates the bench size. The orange shape around the bench indicates the size of the minitower and its viewports (light blue).

the *dual recycled, 125 W AdV configuration*.

After the telescope (after lens L2), the beam has a waist of $260\ \mu\text{m}$, located $\sim 98\ \text{cm}$ after the lens.

The quadrant photodiodes have been placed symmetrically around the waist position, at $\pm z_R$, the Rayleigh range being $z_R = 199\ \text{mm}$. In such configuration, the radius of the beam on the quadrants is $368\ \mu\text{m}$, and the Gouy phase difference between the two quadrants is 90° . The quadrant photodiodes will be used in DC only: no galvanometers are needed on the end benches.

The longitudinal photodiodes have been placed in order to have a beam radius of $300\ \mu\text{m}$ (the goal being between 300 and $400\ \mu\text{m}$).

The cameras have been placed in order to have a beam radius of $\sim 570\ \mu\text{m}$.

The telescope parameters are summarized in appendix [A](#).

4 Suspended PR bench: SPRB

The suspended PR bench (SPRB) will be installed between the PR and BS towers. The minitower viewports are expected to be the same as for the SNEB/SWEB minitowers, except for a symmetry. The minitower position has to take into account space constraints around the PR and BS towers with the PR-BS link tube, and also optical constraints such that the pick-off beam is centered on a viewport. Its precise position still has to be worked-out.

The current layout designed for SPRB is shown in figure 3. Some preliminary remarks can be done:

- the longitudinal and lateral positions of the minitower are not completely defined (need input from mechanics). It will define the exact position of the beam and the viewports position on the minitower.
- the main beam to be analysed on SPRB is B4, the pick-off of the beam resonating inside the recycling cavity. It has to be sent outside the vacuum enclosure in order to be measured via a phase camera.
- additionnally, the possibility to extract the B6/B6p/B9/B9p beams coming from reflections on the compensating plates is studied. These beams could be measured in vacuum on SPRB if needed, or extracted to EPRB1 to measure them outside the vacuum tank.

4.1 SPRB main pick-off beam: B4

The pick-off beam is a fraction of the beam circulated inside the recycling cavity, extracted as a reflection on the surface of the pick-off plate (POP), whose AR coating has a reflection

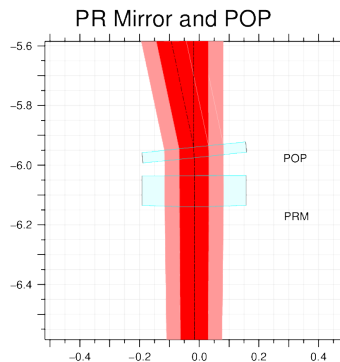

Figure 2: Optocad layout of POP, with the main pick-off beam (B4) extracted.

of 300 ppm (see [1], table 2.9, p.32). The second face of the POP has an AR coating with a reflection lower than 100 ppm and a wedge of 1 mrad from the first face. The extraction of the pick-off beam on the POP is shown figure 2 and the layout of the SPRB bench shown figure 3.

The input beam, coming from the POP, has a waist of 9.6 mm located ~ 1380 m before entering the minitower. Its size at the level of the first face of the double (lens L1a) is 49.5 mm. In the final AdV configuration, the power in the recycling cavity is expected to be 4.9 kW [1]. With a POP reflectivity of 300 ppm, the power of the pick-off beam (B4) is expected to reach up to 1.5 W when entering the SPRB minitower⁴.

After the telescope (after lens L2), the beam has a waist of $\sim 266 \mu\text{m}$, located ~ 100 cm after the lens. The lens has been tilted in order to dump the reflections of all the incoming beams. As a consequence, the beam after L2 has some astigmatism, with waists size difference of $12 \mu\text{m}$ and waist position difference of 56 mm.

The quadrant photodiodes have been placed symmetrically around the waist position, at $\pm z_R$, the Rayleigh range being $z_R \sim 200$ mm. In such configuration, the radius of the beam on the quadrants is $\sim 370 \mu\text{m}$, and the Gouy phase difference between the two quadrants is 87° . The quadrant photodiodes will be used in AC: galvanometers are needed in order to keep the beam position centered on the photodiodes.

The longitudinal photodiodes have been placed in order to have a beam radius of $\sim 340 \mu\text{m}$ (the goal being between 300 and $400 \mu\text{m}$).

The cameras have been placed in order to have a beam radius of $\sim 430 \mu\text{m}$.

The telescope parameters are summarized in appendix B.

The B4 beam has to be sent to the external PR bench (EPRB1) located at the back of the minitower to be analysed using a phase camera. The beam is extracted at the level of the mirror SPRB_M1. Its waists are $272.6 \mu\text{m}$ and $261.0 \mu\text{m}$ in the tangential and sagittal planes, and they are located 219 mm and 201 mm respectively before the position where they hit the beam dump on EPRB1 drawn in the layout. The radius of the beam on the beam dump are $560 \mu\text{m}$ and $643 \mu\text{m}$ respectively.

⁴ $(4.9 \times 10^3) \times (300 \times 10^{-6})$

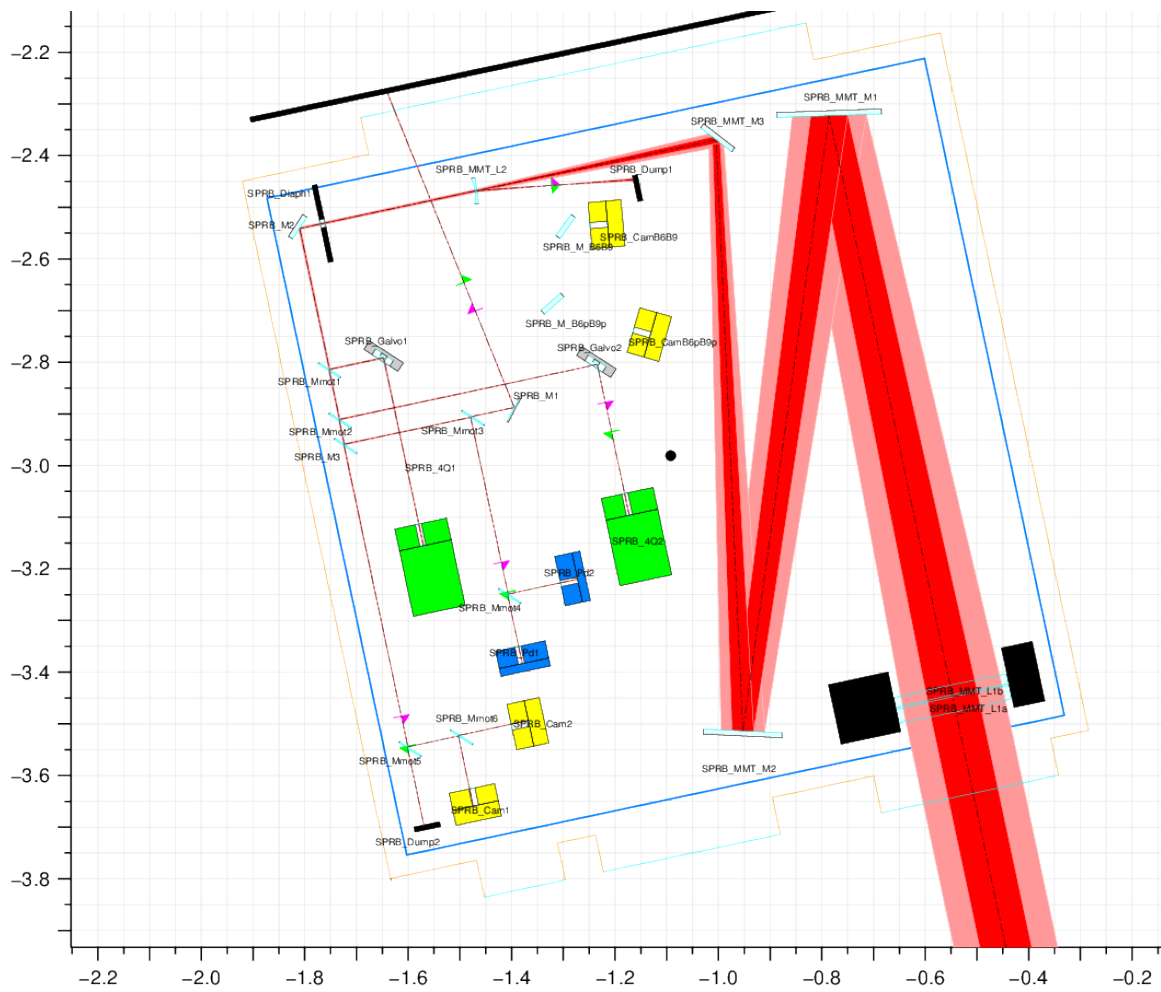

Figure 3: Optocad layout of SPRB with the main pick-off beam (B4). The dark blue square indicates the bench size. The orange shape around the bench indicates the size of the minitower and its viewports (light blue).

4.2 SPRB secondary pick-off beam: B4p

The second face of the PR POP has a coefficient reflection a factor 3 lower than the first face. A secondary beam will thus be reflected at this level, with a power a factor 3 lower, i.e. a power lower of the order of 500 mW. This secondary beam, called B4p, can be separated from B4 thanks to the wedge of the POP, and it has to be dumped.

The layout of SPRB with both B4 and B4p is shown figure 4. The B4p beam can be dumped at the level of the diaphragm at the upper-left corner of the bench: at this level, the B4 beam has a radius of 1.36 mm and the B4p beam a radius of 1.51 mm, and they are separated by 34.7 mm. The numbers are summarized in table 1.

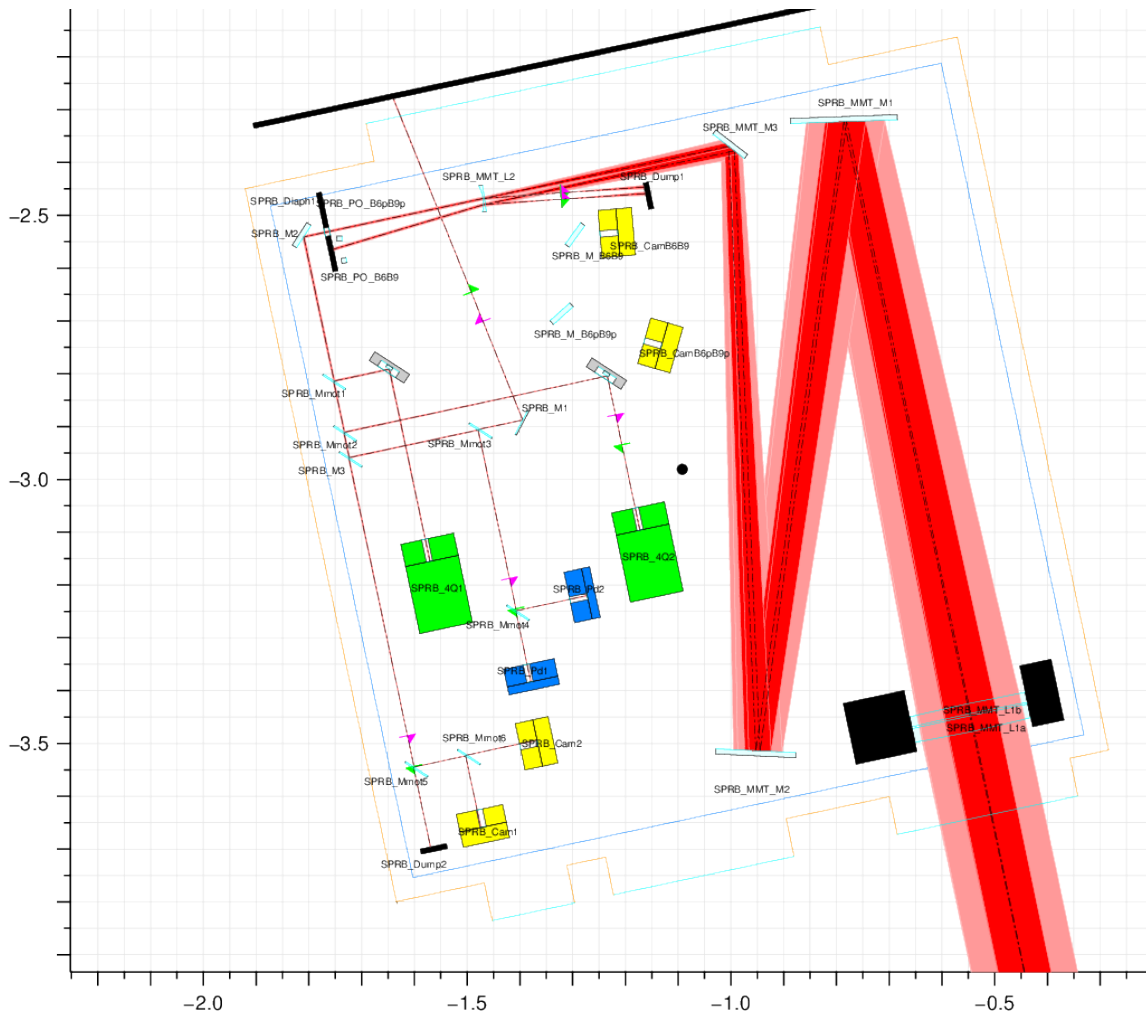

Figure 4: Optocad layout of SPRB with the secondary pick-off beam (B4p). The dark blue square indicates the bench size. The orange shape around the bench indicates the size of the minitower and its viewports (light blue).

4.3 SPRB secondary beams from the CP: B6, B6p, B9 and B9p

The compensating plates (CP) located close to the input mirrors inside the recycling cavity will generate secondary beams inside the cavity. They are tilted by 0.750 mrad [1] and the CP have been ordered with a wedge of $20 \pm 10 \mu\text{rad}$. Some of the secondary beams are reflected on the PR POP and directed towards SPRB. Most of them have to be dumped, but the possibility to extract the CP secondary beams called B6, B6p, B9 and B9p is studied in this section (see figure 7.1, p.236 of [1]). Note that the tilt of the CPs will have a vertical component, such that these beams will not be in the horizontal plane as the main ITF beam and the B4 beams. However, Optocad is a 2D simulation. As a consequence, the Optocad layouts are shown assuming horizontal tilts of the CP and can be used to estimate the beam properties on SPRB and their separation from the B4 beam.

In this study, only the beams from the NI CP (B9 and B9p) will be shown. The beams from the WI CP (B6 and B6p) are supposed to be equivalent.

The wedge of the CP is not included in the standard Optocad simulations.

In the final AdV configuration, the power in the recycling cavity will be 4.9 kW. The AR coating of the CP will have a reflection coefficient lower than 100 ppm and the reflected beams on the CP will cross the BS mirror before reaching the POP. As a consequence, the power of the secondary beams is expected to be of the order of ⁵ $37 \mu\text{W}$. As the two beams reflected from both faces of the CP cannot be separated, the power of the beams will be of the order of $74 \mu\text{W}$.

The power of the same beams, but reflected on the second face of the PR POP will be a factor 3 lower, of the order of $12 \mu\text{W}$.

4.3.1 Beam B9 on SPRB

The B9 beam from the NI CP is reflected on both faces of the PR POP and generates two beams on the SPRB bench as shown in figure 5. The beam reflected on the first face of the POP is called B9 while the beam reflected on the second face is called B9'. In the layout, the B4 and B4p beams are also shown.

The radius of the beams and their distance from the B4 beam are summarized in table 1.

4.3.2 Beam B9p on SPRB

The B9p beam from the NI CP is reflected on both faces of the PR POP and generates two beams on the SPRB bench as shown in figure 6. The beam reflected on the first face of the POP is called B9p while the beam reflected on the second face is called B9p'. In the layout, the B4 and B4p beams are also shown.

Note that in the Optocad 2D simulation, the beams B9 and B9p' are almost superposed, which will not be the case taking into account the vertical tilt of the CPs (see section 4.3.5).

⁵ $(4.9 \times 10^3) \times \frac{1}{2} \times (100 \times 10^{-6}) \times \frac{1}{2} \times (300 \times 10^{-6})$

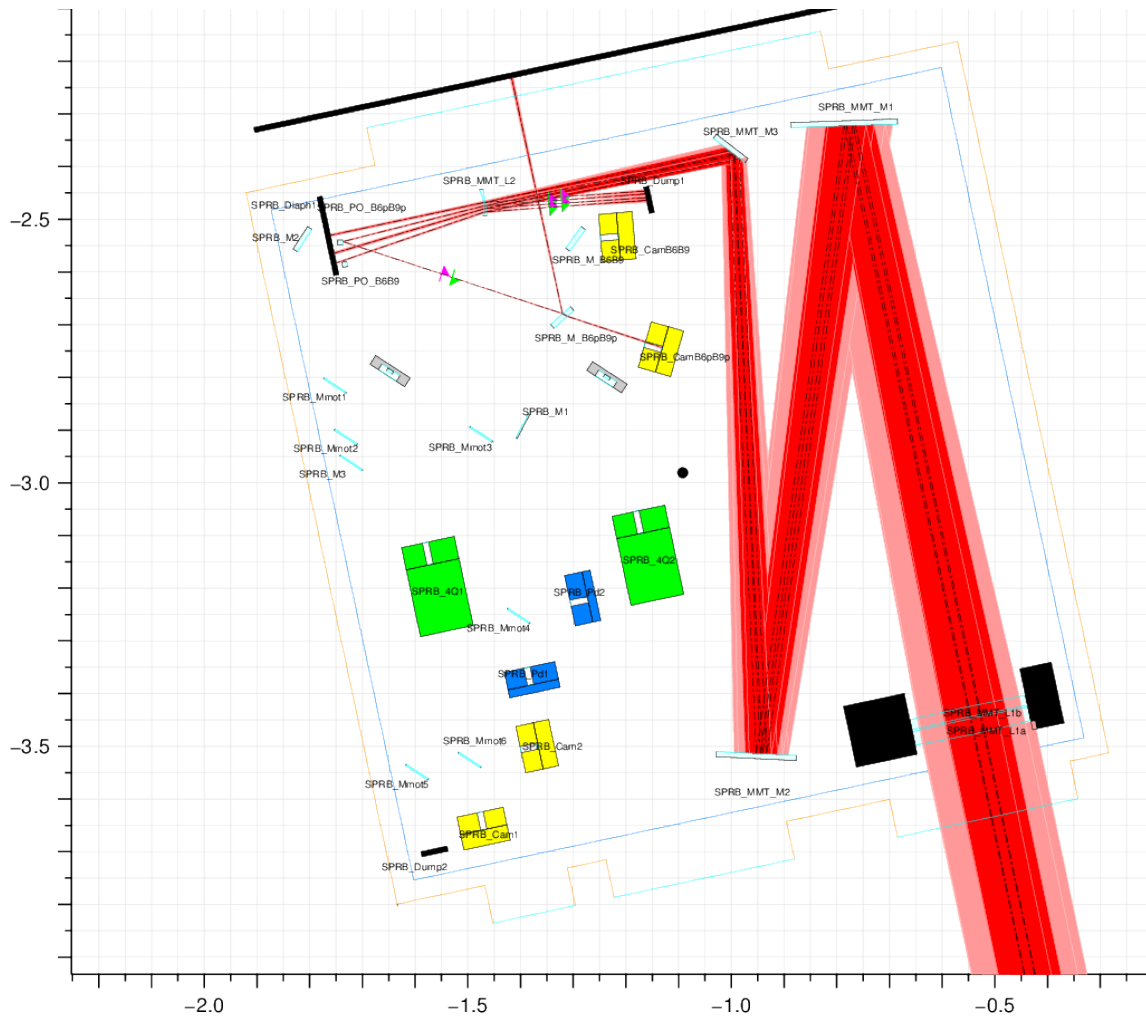

Figure 5: Optocad layout of SPRB with the B4 and B4p beams, along with the B9 beam coming from NI CP, also reflected on both faces of the PR POP. The dark blue square indicates the bench size. The orange shape around the bench indicates the size of the minitower and its viewports (light blue). At the level of the diaphragm, from top to down, the beams are: B4, B9, B4p and B9'.

The radius of the beams and their distance from the B4 beam are summarized in table 1.

4.3.3 Beam B6 and B6p on SPRB

As shown in table 1, it has been checked with Optocad that the B6 and B6p secondary beams coming from the WI CP have the same size on SPRB than the B9 and B9p beams coming from the NI CP, and that they are superposed with them within better than 1 mm.

4.3.4 Beams B9 and B9p on SPRB, with a wedge on the CP

In the latter results, the small wedge of the CP was not taken into account. To confirm that it can be neglected, the effect of a wedge of $20 \mu\text{rad}$ has been studied. It has been temporarily added in Optocad in order to perform CITF simulations⁶. In this case, the reflections from each face of the NI CP are slightly separated at the level of SPRB. Their size and distance from B4 are summarized in table 2: the two B9 beams have a radius of 0.57 mm and are separated by 0.7 mm ; the two B9p beams have a radius of 2.18 mm and are separated by 0.3 mm. Thus the two beams cannot be separated properly.

Comparing the results with and without the CP wedge, the offsets of the beams from B4 are in agreement within less than 1 mm, and there is no significant modification of their size. As a consequence, in the following, the two beams are assumed superposed and the wedge is not taken into account any more.

Table 1: Summary of the beams impinging on the diaphragm of SPRB layout. For each beam, its distance from B4 is given ($d > 0$ for beams below B4 in the layouts), the radius of the beam w , its waist w_0 and the distance D_{waist} of the waist position from the diaphragm are given ($D > 0$ indicates that the waist is located before the diaphragm, i.e. the beam is diverging) In all cases, the values are given for the tangential and sagittal plane.

Beam	Distance (mm)	w t (mm)	w s (mm)	w_0 t (μm)	w_0 s (μm)	D_{waist} t (m)	D_{waist} s (m)
B4	0	1.36	1.34	272.6	261.0	-1.070	-1.013
B4p	+34.7	1.51	1.39	603.8	316.2	-2.459	-1.265
B9	+18.1	0.572	0.538	121.2	114.5	-0.200	-0.178
B9'	+54.4	0.774	0.610	186.8	128.8	-0.414	-0.227
B9p	-17.9	2.18	2.16	638.9	708.9	+3.932	+4.276
B9p'	+16.1	2.23	2.17	424.6	614.0	+2.809	+3.818
B6	+18.03	0.572	0.538	121.1	114.5	-0.200	-0.177
B6'	+54.4	0.775	0.610	186.7	128.8	-0.141	-0.227
B6p	-17.9	2.18	2.16	642.1	707.7	+3.946	+4.269

⁶ since this adding this wedge in the full ITF simulations would require fine-tuning of the alignment of all the CITF towers and benches.

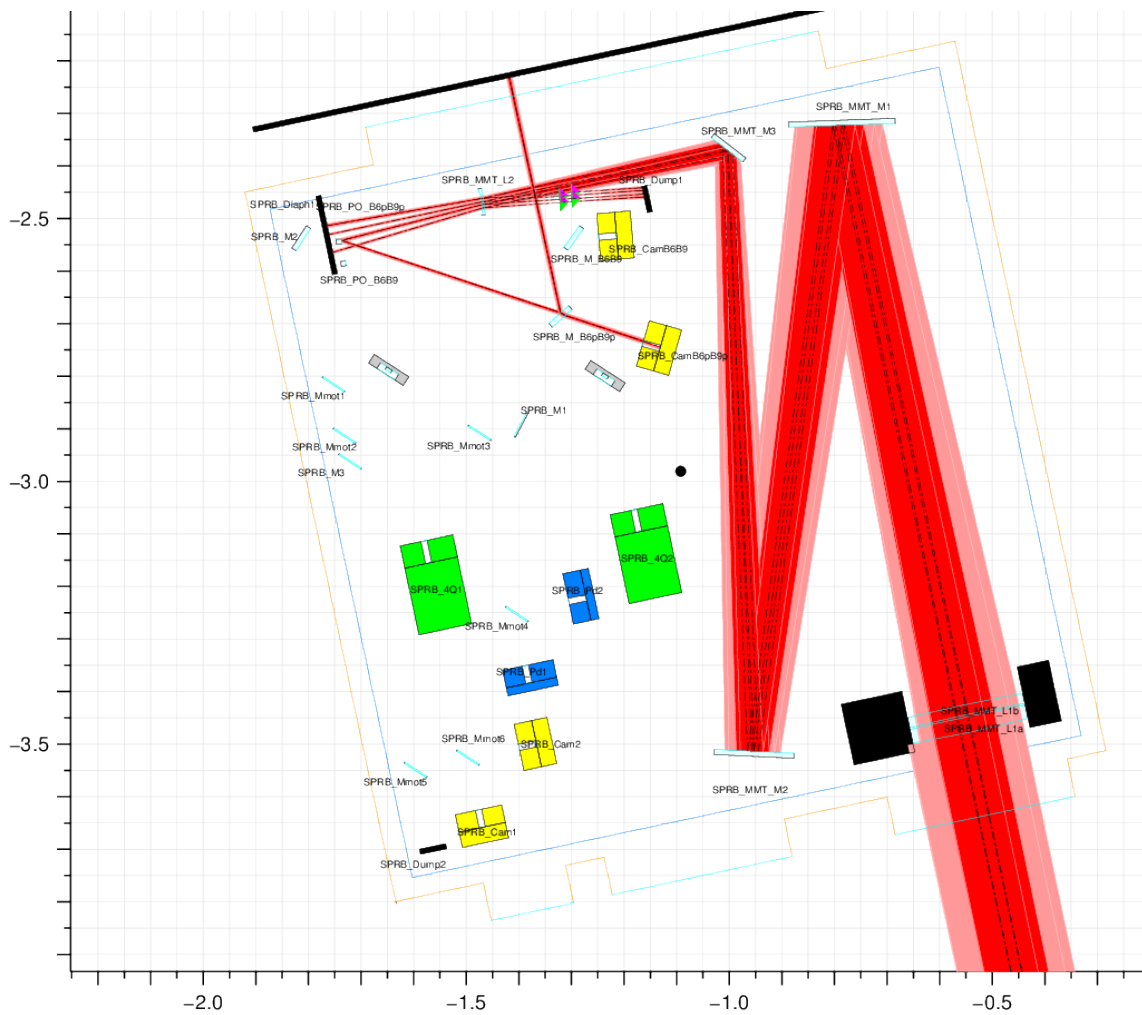

Figure 6: Optocad layout of SPRB with the B4 and B4p beams, along with the B9p beam coming from NI CP, also reflected on both faces of the PR POP. The dark blue square indicates the bench size. The orange shape around the bench indicates the size of the minitower and its viewports (light blue). At the level of the diaphragm, from top to down, the beams are: B9p, B4, B9p' and B4p.

Table 2: Summary of the beams impinging on the diaphragm of SPRB layout with a $20\ \mu\text{rad}$ wedge on the CP. For each beam, its distance from B_4 is given ($d > 0$ for beams below B_4 in the layouts), the radius of the beam w , its waist w_0 and the distance D_{waist} of the waist position from the diaphragm are given ($D > 0$ indicates that the waist is located before the diaphragm, i.e. the beam is diverging) In all cases, the values are given for the tangential and sagittal plane.

Beam	Distance (mm)	w t (mm)	w s (mm)	w_0 t (μm)	w_0 s (μm)	D_{waist} t (m)	D_{waist} s (m)
B9	+17.56	0.571	0.537	120.9	114.4	-0.199	-0.177
	+18.27	0.572	0.538	121.3	114.5	-0.200	-0.178
B9p	-17.0	2.18	2.16	647.3	713.2	+3.975	+4.297
	-17.7	2.18	2.16	641.0	709.9	+3.942	+4.281

4.3.5 Realistic visualizations of all the beams on L2 and on the diaphragm

In the previous sections, the simulations of the secondary beams from the pick-off were done in 2D with Optocad. Since the tilt of the CPs will have a vertical component, a tentative 3D estimation of the beam locations at the level of the diaphragm on SPRB is drawn in this section.

The total tilt of the CPs is $0.750\ \text{mrad}$, and it was simulated only as an horizontal tilt (around θ_y) in Optocad. In order to separate the secondary beams, the tilt of the CP can be set as $650\ \mu\text{rad}$ in θ_x (vertical tilt) and $375\ \mu\text{rad}$ in θ_y (horizontal tilt).

Realistic visualization of all the beams at the level of the lens L2— In this case, the distances between the B4 beam and the secondary beams reflected on the first face of the POP must be the same as in the Optocad simulations, but they are not in the horizontal plane. The positions of the beams at the level of the lens L2 are given in the table 3. The expected positions of the beam around B4 are shown in the figure 7(a), as well as their expected beam size at $1 w_0$ and $4 w_0$.

Concerning the beams reflected on the second face of the POP, the Optocad simulations are correct for the beam B4p. For the other beams, neglecting the small differences of incidence angles of all the beams on the POP, we can assume that they are offset horizontally by the same amount than the B4p beam vs the B4 beam, i.e. $11.7\ \text{mm}$. This is confirmed by the numbers in the table 3: the distances B9 to B9' and B9p to B9p' are also $11.7\ \text{mm}$. In the figure 7(a), the positions of the secondary beams shown on the left part are thus the same as the positions of the primary beams, but translated by $11.7\ \text{mm}$. The size of the beams have been modified according to the table 3.

This study shows that the size of the lens L2 have to be $2''$ if one wants to extract the secondary beams from the CP. In case they are not extracted, a lens L2 of $1''$ would be enough, and a diaphragm to reduce the aperture would be needed in front of it to dump the beam B4p.

Realistic visualization of all the beams at the level of the diaphragm – The same study has been made in order to estimate the beam positions when impinging on the diaphragm. The table 1 gives the distance of the beams from B4 and their radius on the diaphragm. With the same hypothesis than for the visualization of the beams on the lens L2, the positions of the beams on the diaphragm have been estimated and drawn in figure 7(b). The positions of the secondary beams shown on the left part are thus the same as the positions of the primary beams, but translated by 34.7 mm. The size of the beams have been modified according to the table 1.

This sketch shows that the beams can be separated enough at the level of the diaphragm to be either dumped or extracted to measure them. In any case, B4p will be dumped. The extraction of the B6, B6p, B9 and B9p beam can be done either on the beam reflected on the first face of the POP or on the second face of the POP, their power being a factor 3 lower.

Table 3: Summary of the beams impinging on the lens MMT_L2 of SPRB layout. For each beam, its distance from B4 is given ($d > 0$ for beams below B4 in the layouts) and the radius of the beam w (in the tangential and sagittal plane).

Beam	Distance (mm)	w_t (mm)	w_s (mm)
B4	0	1.74	1.74
B4p	+11.7	1.73	1.73
B9	+6.7	1.43	1.43
B9'	+18.3	1.42	1.42
B9p	-6.7	2.06	2.06
B9p'	+5.0	2.05	2.05

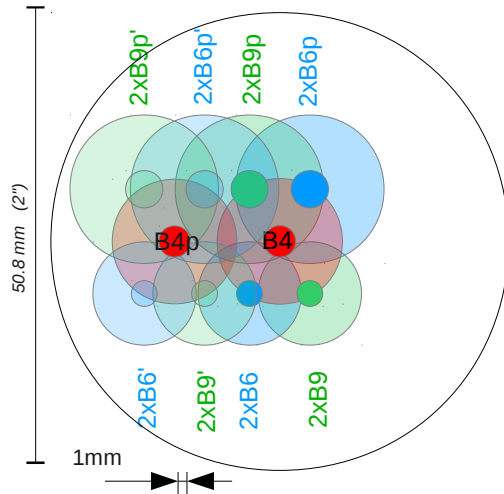

(a) Beams on L2

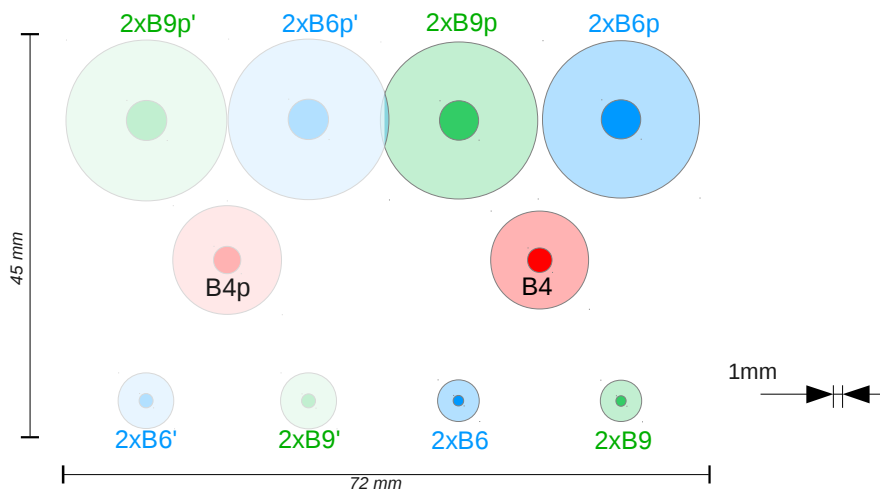

(b) Beams on the diaphragm

Figure 7: Schematic drawings of the B_4 and B_{4p} beams from the POP, as well as of the secondary beams from the CPs, (a) in the plane of the lens L2, viewed from the mirror M3 to the lens and (b) in the plane of the diaphragm on SPRB, viewed from the lens L2 to the diaphragm. The beam sizes are drawn at $1w_0$ and $4w_0$. In (a), the size of the lens L2 of 2" centered on B_4 is shown.

References

- [1] The Virgo collaboration, *Advanced Virgo Technical Design Report* (2012) [VIR-0128A-12](#).
- [2] A. Bertolini et al., *Report of the tests made on the two first minitowers and foreseen modifications on the three remaining ones* (2013) [Virgo note VIR-0207A-13](#).
- [3] R. Gouaty, *DET status* (2013) [Virgo talk VIR-0161A-13](#).

A SNEB/SWEB telescope parameters

The parameters of the SNEB (and SWEB) telescope are summarized in this appendix.

- SNEB_MMT_L1a:
 - 1st face ROC: 2188 mm
 - 2nd face ROC: 7334.5 mm
 - Thickness: 30 mm
 - Size of the beam: 58.8 mm (beam waist: 6.68 mm, located 1155 mm before the 1st surface)
 - Aperture: \sim 224 mm diameter (3.8 waist)
 - Beam height: 120 mm above the bench surface.
- SNEB_MMT_L1b:
 - 1st face ROC: -2979 mm
 - 2nd face ROC: 4500 mm
 - Thickness: 19 mm
 - Beam height: 120 mm above the bench surface.
- SNEB_MMT_M1:
 - flat mirror, rotated of 7.7° in θ_y (and $\sim 0.5^\circ$ in θ_x , towards bottom).
 - incidence angle of the beam: 7.7° (neglecting the θ_x angle)
 - size of the beam: 43.3 mm
 - aperture equivalent to doublet: 6.5". Final size: 8".
 - Beam height: 120 mm above the bench surface.
- SNEB_MMT_M2
 - flat mirror, rotated of 21.3° in θ_y (and $\sim 0.5^\circ$ in θ_x , towards top).
 - incidence angle of the beam: 5.9° (neglecting the θ_x angle)
 - size of the beam: 26.6 mm
 - aperture equivalent to doublet: 4.0". Final size: 6".
 - Beam height: 100 mm above the bench surface.
- SNEB_MMT_M3:

- flat mirror, rotated of 13.6015° in θ_y .
- incidence angle of the beam: 13.60°
- size of the beam: 8.5 mm
- aperture equivalent to doublet: 1.3". Final size: 2" or 3" (as in SPRB) ?
- Beam height: 100 mm above the bench surface.
- SNEB_MMT_L2:
 - focal length: -100.9 mm
 - size of the beam: 1.33 mm
 - aperture equivalent to doublet: 0.3". Final size: 1" or 2" (as in SPRB) ?

The optical distances along the beam path between the optical elements are (given by Optocad, neglecting the M1 and M2 tilts in θ_x):

- L1a 2nd face to L1b 1st face: 4.319 mm (this parameter can be modified depending on the mechanical mount of the doublet).
- L1b 2nd face to L2 1st face: 4003 mm (L1b to M1: 1057 mm, M1 to M2: 1172 mm, M2 to M3: 1270 mm, M3 to L2 1st face: 504 mm)

In practice, the beam between M1 and M2 also have a vertical direction: it goes down by 2 cm along the 1172 mm horizontal distance. This does not modify significantly the optical distance from M1 to M2 (less than $200 \mu\text{m}$).

Positions of the different optical telescope elements taking as origin the center of the SNEB bench (extracted from Optocad):

- Center of 1st face of L1a: $x = 110 \text{ mm}$, $y = -530 \text{ mm}$, $z = 120 \text{ mm}$
- Center of 1st face of L1b: $x = 110 \text{ mm}$, $y = -495.68 \text{ mm}$, $z = 120 \text{ mm}$
- Center of HR face of M1: $x = 110 \text{ mm}$, $y = 580 \text{ mm}$, $z = 100 \text{ mm}$ (inclination 7.7° and $\sim 0.5^\circ$)
- Center of HR face of M2: $x = 421.1 \text{ mm}$, $y = -550 \text{ mm}$, $z = 100 \text{ mm}$ (inclination 21.3° and $\sim 0.5^\circ$)
- Center of HR face of M3: $x = -159.5 \text{ mm}$, $y = 580 \text{ mm}$, $z = 100 \text{ mm}$ (inclination 13.6015°)
- Center of 1st face of L2: $x = -159.44 \text{ mm}$, $y = 0.076 \text{ m}$

B SPRB telescope parameters

The parameters of the SPRB telescope are summarized in this appendix.

- SPRB_MMT_L1a:
 - 1st face ROC: 2188 mm
 - 2nd face ROC: 7334.5 mm
 - Thickness: 30 mm
 - Size of the beam: 49.3 mm (beam waist: 9.68 mm, located 1382 mm before the 1st surface)
 - Aperture: 224 mm diameter (4.5 waist)
 - Beam height: 120 mm above the bench surface.
- SPRB_MMT_L1b:
 - 1st face ROC: -2979 mm
 - 2nd face ROC: 4500 mm
 - Thickness: 19 m
 - Beam height: 120 mm above the bench surface.
- SPRB_MMT_M1:
 - flat mirror, rotated of 10° in θ_y (and $\sim 0.5^\circ$ in θ_x , towards bottom).
 - incidence angle of the beam: 10°
 - size of the beam: 35.5 mm
 - aperture equivalent to doublet: 6.5" -> 8"
 - Beam height: 120 mm above the bench surface.
- SPRB_MMT_M2
 - flat mirror, rotated of 14.7° in θ_y (and $\sim 0.5^\circ$ in θ_x , towards top).
 - incidence angle of the beam: 5.3°
 - size of the beam: 21.1 mm
 - aperture equivalent to doublet: 3.8" -> 6"
 - Beam height: 100 mm above the bench surface.
- SPRB_MMT_M3

- flat mirror, rotated of 4.709°
 - incidence angle of the beam: 40.3°
 - size of the beam: 7.4 mm
 - aperture equivalent to doublet: 2.6 " -> 3"
 - Beam height: 100 mm above the bench surface.
- SPRB_MMT_L2
 - first face ROC: flat surface
 - second face ROC: -0.0727 m
 - rotated of 40.29° , incidence angle of the beam: 4°
 - size of the beam: 1.74 mm
 - aperture equivalent to doublet: 0.31". However, an aperture of 2" will be used due to the presence of the secondary beams from the CP (B6, B6p, B9, B9p).

The optical distances along the beam path between the optical elements are (given by Optocad, neglecting the M1 and M2 tilts in θ_x):

- L1a 2nd face to L1b 1st face: 4.319 mm (this parameter can be modified depending on the mechanical mount of the doublet).
- L1b 2nd face to L2 1st face: 3952 mm (L1b to M1: 1127 mm, M1 to M2: 1202 mm, M2 to M3: 1145 mm, M3 to L2 1st face: 478 mm)

In practice, the beam between M1 and M2 also have a vertical direction: it goes down by 2 cm along the 1202 mm horizontal distance. This does not modify significantly the optical distance from M1 to M2 (less than $200 \mu\text{m}$).

Positions of the different optical telescope elements taking as origin the center of the SPRB bench (extracted from Optocad):

- Center of 1st face of L1a: $x = 446 \text{ mm}$, $y = -600 \text{ mm}$, $z = 120 \text{ mm}$
- Center of 1st face of L1b: $x = 446 \text{ mm}$, $y = -565.7 \text{ mm}$, $z = 120 \text{ mm}$
- Center of HR face of M1: $x = 446 \text{ mm}$, $y = 580 \text{ mm}$, $z = 100 \text{ mm}$ (inclination 10° and $\sim 0.5^\circ$)

- Center of HR face of M2: $x = 35.5$ mm, $y = -550$ mm, $z = 100$ mm (inclination 14.7° and $\sim 0.5^\circ$)
- Center of HR face of M3: $x = 223$ mm, $y = 580$ mm, $z = 100$ mm (inclination 40.3°)
- Center of 1st face of L2: $x = -250$ mm, $y = 580$ m, $z = 100$ mm