

CNRS

Centre National de la Recherche Scientifique

INFN

Istituto Nazionale di Fisica Nucleare



Stable Recycling Cavities : L.R.C. *vs* S.R.C. angular requirements

VIR-0029A-11

M. Mantovani

Issue: 1

Date: February 4, 2011

VIRGO * A joint CNRS-INFN Project
Via E. Amaldi, I-56021 S. Stefano a Macerata - Cascina (Pisa)
Secretariat: Telephone (39) 050 752 521 * FAX (39) 050 752 550 * Email W3@virgo.infn.it

Contents

1	Introduction	3
2	Short Recycling Cavity requirements - S.R.C.	4
2.1	Power recycling cavity - S.R.C.	4
2.2	Signal recycling cavity - S.R.C.	5
2.2.1	SRC power losses	6
2.2.2	Sensitivity relative variation	7
2.3	Vertical and Horizontal displacement requirements - S.R.C.	8
3	Long Recycling Cavities requirements - L.R.C.	9
3.1	Power recycling cavity - L.R.C.	9
3.2	Vertical and Horizontal displacement requirements - L.R.C.	10
4	Conclusions	11
5	Acknowledgements	11
A	Locking	12
B	pitch and yaw directions	15
C	multiple mirror misalignment effect	17

The Advanced Virgo optical design consists of a Michelson interferometer with two 3 km long Fabry-Perot cavities on its arms, a Power Recycling (PRC) and a Signal Recycling (SRC) cavities. The main differences between the Advanced Virgo configuration and the present Virgo interferometer one are: the presence, within the optical scheme, of the Non-Degenerate Recycling Cavities (NDRC), a higher power stored in the cavities and the presence of the Signal Recycling cavity.

These changes produce an improvement in the interferometer stability and sensitivity but an increase of complexity in the development of the Automatic Alignment control system.

- **NDRC configuration for the Power and Signal recycling cavities:** Stable Non-Degenerate cavities are less affected by the thermal effects since the high-order modes are filtered by the cavity itself. On the other hand, by reducing the higher order modes contents, the Automatic Alignment error signals amplitude is reduced (since these are proportional to the amount of the $TEM_{01/10}$ modes). Moreover, with the new configuration, each recycling cavity is composed by three mirrors and then a larger number of angular degrees of freedom have to be considered in the automatic alignment process.
- **High circulating power:** The high amount of laser power circulating in the interferometer has been meant to reduce the shot noise contribute in the gravitational wave signal. On the other hand the high amount of laser power produces a higher level of radiation pressure noise modifying the mechanical Transfer Function of the angular degrees of freedom. These changes have to be taken into account in the control system design.
- **Presence of Signal Recycling:** The Signal Recycling technique (also known as dual recycling) consists of adding a new cavity (SRC) at the output port of the interferometer. Basically, if the SRC is made resonant for a gravitational wave sideband frequency, there is an enhancement in the response of the detector at this frequency at the cost of bandwidth. If the SRC is tuned to anti-resonance the bandwidth of the detector is widened in comparison to the standard case (with the Power Recycling cavity only). The anti-resonance configuration is usually called Resonant Sideband Extraction. The use of a Signal Recycling Cavity, which will be detuned from resonance in Advanced Virgo, allows the improvement of the interferometer sensitivity in a selected frequency region. This positive aspect should be carefully handled with the presence of the signal recycling mirror which increases the number of degrees of freedom to be controlled by the automatic alignment system.

Within the context summarized above and with the goal to ensure long data tacking periods keeping the interferometer on its working point, the main mirrors have to be globally aligned with respect to the laser beam and a more sophisticated angular control system has to be implemented. To this purpose, it should be effective reducing the mirror misalignments in the frequency region where the Superattenuator does not fulfill the alignment requirements (in the region below a few Hz, where the mechanical resonances are confined). An accurate design study of the Automatic Alignment control system is a fundamental step to determine the needed alignment accuracy avoiding the interferometer sensitivity spoiling. The evaluation of the requirements for the recycling mirrors (for PRC and SRC) is the aim of this note.

1 Introduction

In this Virgo note the angular accuracy requirements for the advanced Virgo recycling cavity mirrors have been evaluated both for the Short-Recycling-Cavity and the Long-Recycling-Cavity designs. The requirements have been evaluated for the angular directions, pitch and yaw, and for the vertical and horizontal directions for the three Signal Recycling cavity mirrors (SRM1, SRM2 and SRM3) and for the three Power Recycling cavity mirrors (PRM1, PRM2 and PRM3) in case of Short-Recycling-Cavity and only for the Power Recycling cavity mirrors in case of Long-Recycling-Cavity.

In order to reduce the confusion, the acronyms used for Short Recycling Cavity and Long Recycling Cavity will be S.R.C. and L.R.C. respectively, while the acronyms used for Signal Recycling cavity and Power Recycling cavity will be SRC and PRC respectively.

The requirements for the RMS accuracy of the cavity mirrors are set in order to have acceptable fluctuations for the carrier and the sidebands in the cavities of the order of 10^{-3} , as was done in the previous Virgo note [1]. Moreover for the Signal recycling mirrors the requirements for the accuracy of the angular displacement of the mirrors has to be set in order to do not vary the sensitivity more than a factor 10^{-2} .

The results are obtained using frequency domain simulation tool Finesse [2]. The finesse files have been built, tuned and verified by Julien Marque and in the simulations the lock has been maintained active on the Darm, Carm, PR and SR longitudinal d.o.f.

2 Short Recycling Cavity requirements - S.R.C.

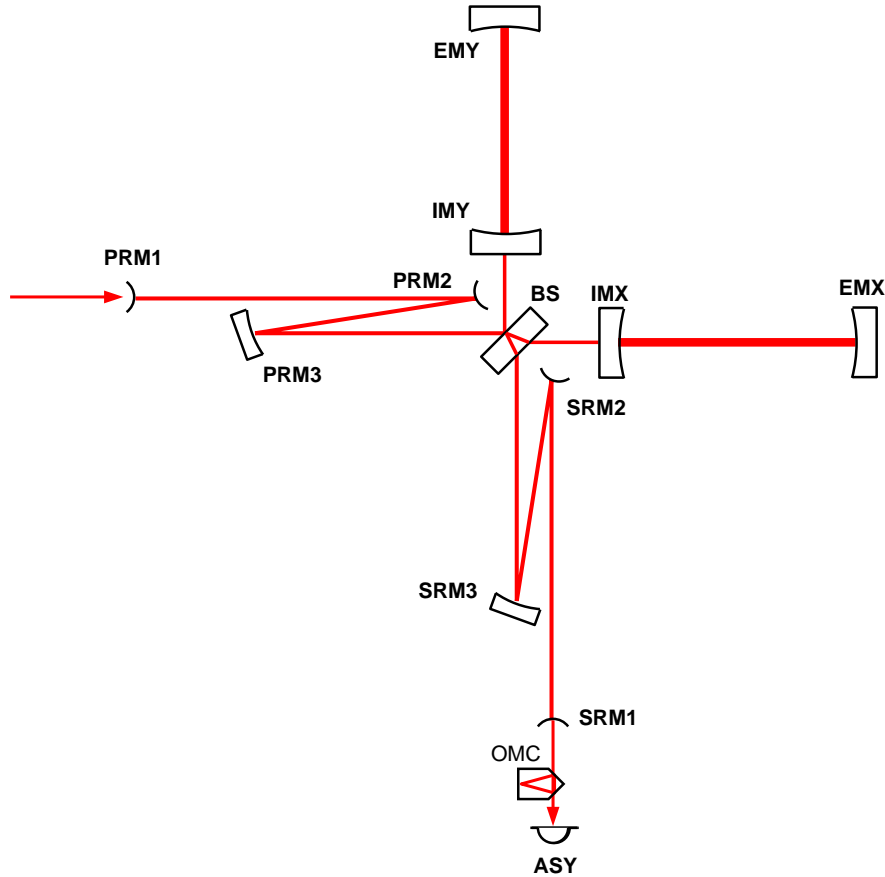

Figure 1: Advanced Virgo optical configuration in the Non-Degenerate recycling cavities configuration.

PRM1 ROC	1.8175 m	PRM2 ROC	1.8175 m	PRM3 ROC	15.081 m
SRM1 ROC	1.8118 m	SRM2 ROC	1.8118 m	SRM3 ROC	14.314 m
PRCL1	6.780 m	PRCL2	6.780 m	PRCL3	10.703 m
SRCL1	6.473 m	SRCL2	6.395 m	SRCL3	10.686 m

Table 1: Optical parameter for the Signal Recycling Cavity and the Power Recycling cavity.

The optical configuration for S.R.C. is shown in Figure 1 and the parameters are listed in Table 1.

2.1 Power recycling cavity - S.R.C.

In order to set the angular accuracy requirements for the three cavity mirrors (PRM1, PRM2 and PRM3) the power losses in the power recycling cavity have been computed for the sidebands and the carrier. The sidebands considered in this computation are the ones generated by the first modulation frequency (7470160 Hz) which are resonating in the PRC.

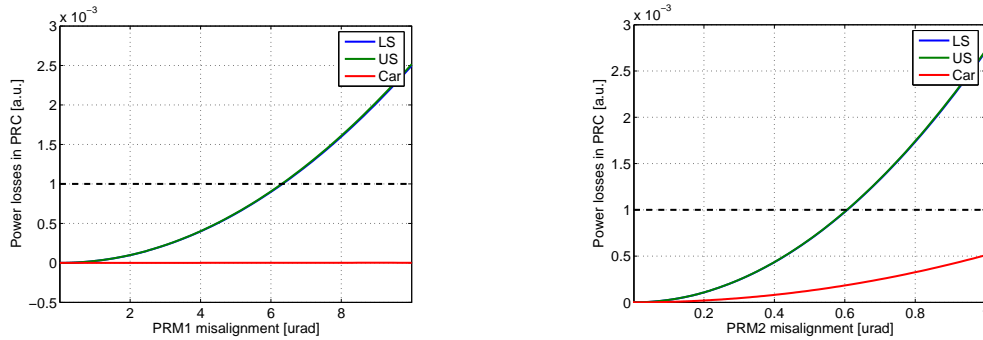

Figure 2: Power Recycling cavity losses as a function of the PRM1 mirror misalignment in the pitch direction (left plot) and as a function of the PRM2 misalignment (right plot). The dashed black line represents the maximum acceptable cavity losses.

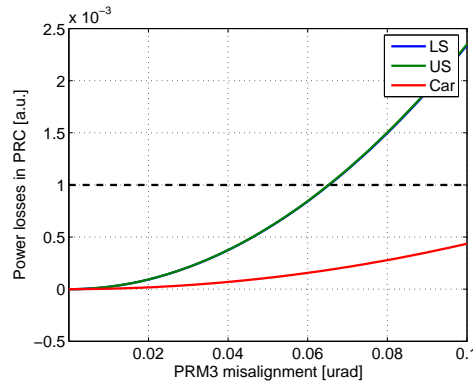

Figure 3: Power Recycling cavity losses as a function of the PRM3 mirror misalignment in the pitch direction. The dashed black line represents the maximum acceptable cavity losses.

mirror	RMS [μrad]	mirror	RMS [μrad]	mirror	RMS [μrad]
PRM1	5	PRM2	0.5	PRM3	0.05

Table 2: Requirements for the Power Recycling mirrors RMS. The values are slightly lower to the ones shown in the Figures 2 and 3 to be more conservative and to take into account the fact that in the yaw directions the requirements are a little bit more stringent, see Appendix B.

The requirements shown in Table 2 are slightly lower to the ones shown in the Figures 2 and 3 to be more conservative and to take into account the fact that in the yaw directions the requirements are a little bit more stringent, see Appendix B.

Moreover they seems to be more relaxed with respect to the ones found in the previous Virgo note [1], this fact is due to the longitudinal control active on the cavity lengths, see Appendix A for more details.

2.2 Signal recycling cavity - S.R.C.

As it has been anticipated in the introduction, section 1, for the Signal Recycling cavity mirrors the accuracy requirements for the angular directions have to make the cavity losses less than 10^{-3} and the sensitivity relative variation less than 1%.

2.2.1 SRC power losses

In order to set the angular accuracy requirements for the three cavity mirrors (SRM1, SRM2 and SRM3) the power losses in the power recycling cavity have been computed for the sidebands and the carrier. The sidebands considered in this computation are the ones generated by the second modulation frequency (82171760 Hz) which are resonating in the SRC.

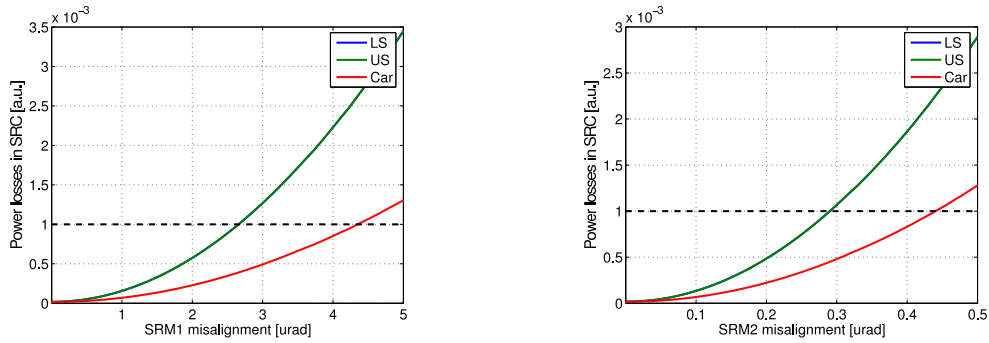

Figure 4: Signal Recycling cavity losses as a function of the SRM1 mirror misalignment in the pitch direction (left plot) and as a function of the SRM2 misalignment (right plot). The dashed black line represents the maximum acceptable cavity losses.

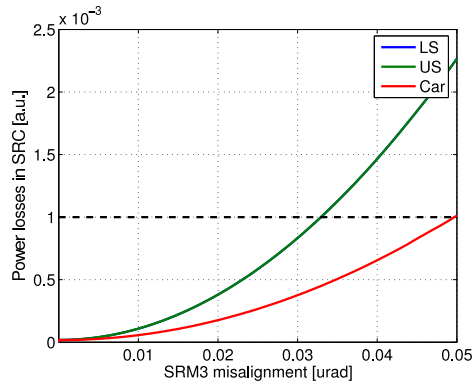

Figure 5: Signal Recycling cavity losses as a function of the SRM3 mirror misalignment in the pitch direction. The dashed black line represents the maximum acceptable cavity losses.

2.2.2 Sensitivity relative variation

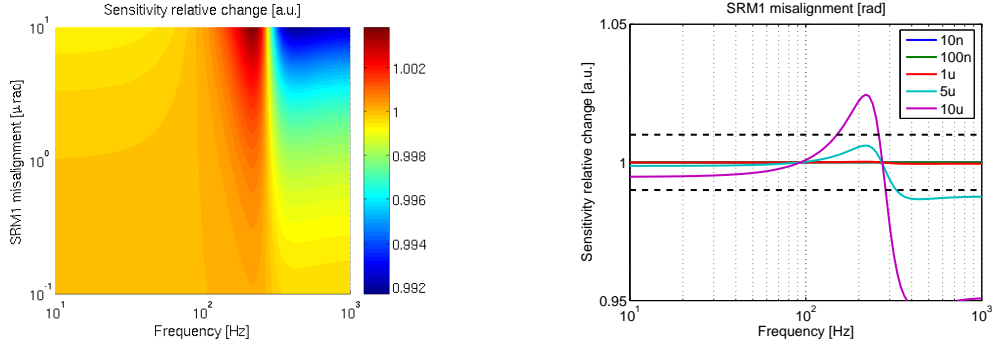

Figure 6: Sensitivity relative variation in a 3D plot on the left as a function of the frequency and of the SRM1 misalignment. On the right the sensitivity variation is shown for various SRM1 misalignments.

For a misalignment of a mirror in the SRC, the sensitivity does not varies with respect to the one obtained in a perfectly aligned configuration in the same way for all the frequencies. As it is shown in Figure 6 the sensitivity variation can be studied by looking at four frequencies: 100 Hz, 250 Hz, 450 Hz and 1000 Hz.

At these frequencies the sensitivity variation, especially at 250 and 450 Hz, reaches the larger values.

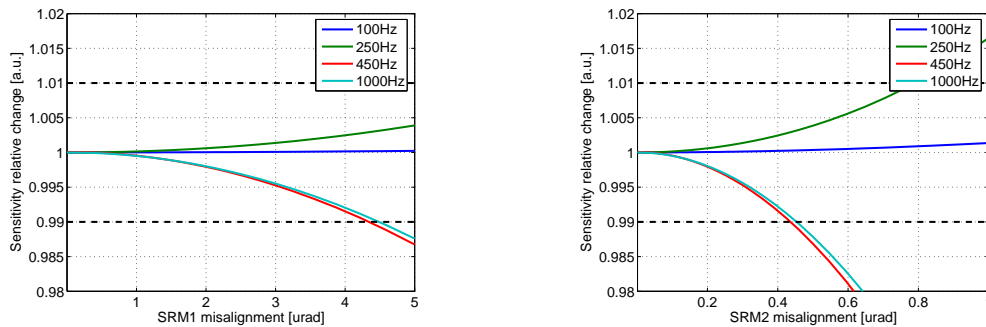

Figure 7: Sensitivity relative variation at 100, 250, 450 and 1000 Hz as a function of the SRM1 misalignment (left plot) and the SRM2 misalignment (right plot). The misalignment exceed the requirements if the sensitivity variation overcomes the black dashed lines.

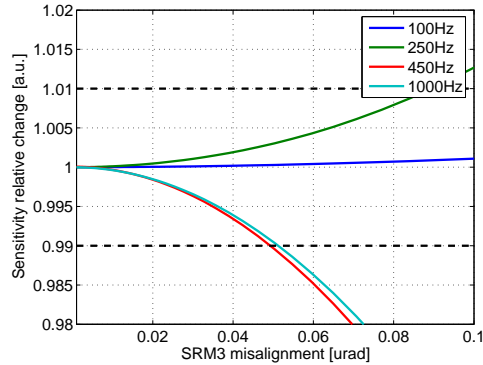

Figure 8: Sensitivity relative variation at 100, 250, 450 and 1000 Hz as a function of the SRM3 misalignment . The misalignment exceed the requirements if the sensitivity variation overcomes the black dashed lines.

The Signal recycling mirror angular requirements can then be set as:

mirror	RMS [μrad]	mirror	RMS [μrad]	mirror	RMS [μrad]
SRM1	2	SRM2	0.25	SRM3	0.03

Table 3: Requirements for the Signal Recycling mirrors RMS.

2.3 Vertical and Horizontal displacement requirements - S.R.C.

In the Stable Recycling cavities the angular directions are strongly coupled with the horizontal and vertical directions due to the short radii of curvature chosen for the cavity mirrors, as it is shown in [3]. A translation of a curved mirror is seen by the optical system as a tilt of the mirror of an equivalent angle as:

$$\hat{\theta}_i = x_i/R_C \quad (1)$$

Where x_i is the vertical or horizontal displacement of the i-mirror, R_C is the radius of curvature of the i-mirror and $\hat{\theta}_i$ is the equivalent pitch or yaw displacement of the i-mirror.

Thanks to the Equation 1 the requirements on the vertical and horizontal displacement for the PRC and SRC mirrors can be set as:

mirror	RMS [μm]	mirror	RMS [μm]	mirror	RMS [μm]
PRM1	9	PRM2	0.9	PRM3	0.75
SRM1	3.6	SRM2	0.45	SRM3	0.43

Table 4: Requirements for the Signal Recycling mirrors vertical and horizontal RMS.

3 Long Recycling Cavities requirements - L.R.C.

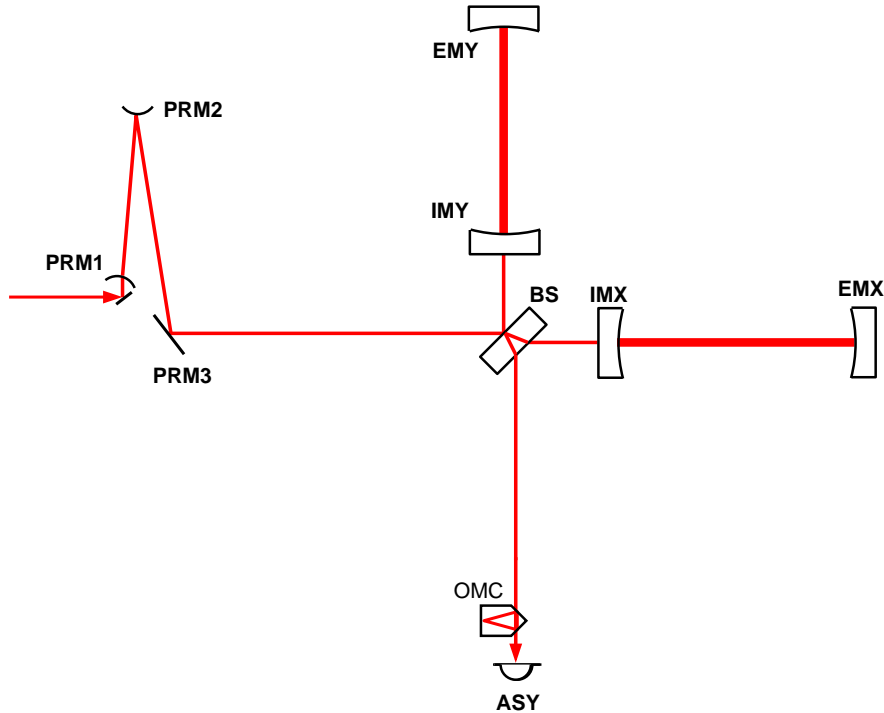

Figure 9: Advanced Virgo optical configuration in the Non-Degenerate recycling cavities configuration.

PRM1 ROC	1.71 m	PRM2 ROC	136.745 m	PRM3 ROC	∞
PRCL1	70.222 m	PRCL2	70.161 m	PRCL3	6.927 m

Table 5: Optical parameter for the Signal Recycling Cavity and the Power Recycling cavity.

The optical configuration for S.R.C. is shown in Figure 1 and the parameters are listed in Table 1.

3.1 Power recycling cavity - L.R.C.

In order to set the angular accuracy requirements for the three cavity mirrors (PRM1, PRM2 and PRM3) the power losses in the power recycling cavity have been computed for the sidebands and the carrier. The sidebands considered in this computation are the ones generated by the first modulation frequency (8319645 Hz) which are resonating in the PRC.

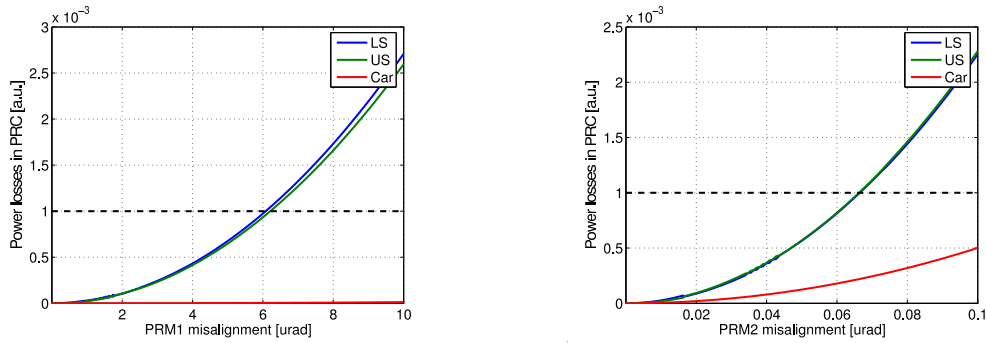

Figure 10: Power Recycling cavity losses as a function of the PRM1 mirror misalignment in the pitch direction (left plot) and as a function of the PRM2 misalignment (right plot). The dashed black line represents the maximum acceptable cavity losses.

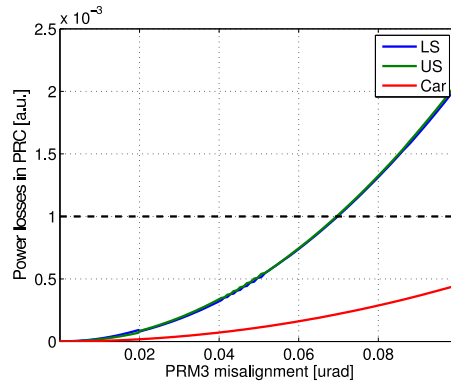

Figure 11: Power Recycling cavity losses as a function of the PRM3 mirror misalignment in the pitch direction. The dashed black line represents the maximum acceptable cavity losses.

mirror	RMS [μrad]	mirror	RMS [μrad]	mirror	RMS [μrad]
PRM1	5	PRM2	0.06	PRM3	0.06

Table 6: Requirements for the Power Recycling mirrors RMS in the L.R.C. configuration. The values are slightly lower to the ones shown in the Figures 10 and 11 to be more conservative.

The requirements shown in Table 6 shows a more stringent requirement for the PRM2 in case of L.R.C. with respect to S.R.C. configuration, of about a factor 10.

3.2 Vertical and Horizontal displacement requirements - L.R.C.

The vertical and horizontal requirements are computed as before, and since the PRM2 and PRM3 radii of curvature are large the transversal displacement requirements are not stringent at all.

mirror	RMS [μrad]	mirror	RMS [μrad]	mirror	RMS [μrad]
PRM1	8.6	PRM2	8	PRM3	∞

Table 7: Requirements for the Power Recycling mirrors vertical and horizontal RMS.

4 Conclusions

In this note the accuracy requirements for the recycling cavity mirrors have been evaluated for two different optical configurations:

- PRM1, PRM2, PRM3, SRM1, SRM2 and SRM3 for the Short Recycling Cavity design
- PRM1, PRM2 and PRM3 for the Long Recycling Cavity design

The requirements have been set for the angular directions, pitch and yaw, and for the mirror shift, in horizontal and vertical directions, as:

S.R.C.					
mirror (tilt)	RMS [μrad]	mirror	RMS [μrad]	mirror	RMS [μrad]
PRM1	5	PRM2	0.5	PRM3	0.05
SRM1	2	SRM2	0.25	SRM3	0.03
mirror (shift)	RMS [μm]	mirror	RMS [μm]	mirror	RMS [μm]
PRM1	9	PRM2	0.9	PRM3	0.75
SRM1	3.6	SRM2	0.45	SRM3	0.43
L.R.C.					
mirror (tilt)	RMS [μrad]	mirror	RMS [μrad]	mirror	RMS [μrad]
PRM1	5	PRM2	0.06	PRM3	0.06
mirror (shift)	RMS [μm]	mirror	RMS [μm]	mirror	RMS [μm]
PRM1	8.6	PRM2	8	PRM3	∞

Table 8: Requirements for the Recycling cavity mirrors vertical and horizontal RMS.

The two main differences for the angular/transversal requirements in the two configurations are:

- The higher accuracy needed for the PRM2 mirror in the L.R.C. scheme with respect to the one needed in the S.R.C. scheme (0.06 μrad with respect to 0.5 μrad , see Table 8)
- The lower accuracy needed for the transversal displacements, i.e. along horizontal and vertical directions, in the L.R.C. scheme with respect to the S.R.C. scheme ¹

Both of the designs result to be challenging for the angular control. The Short Recycling Cavity is challenging especially for the strong coupling of the transversal displacement of the mirror with the angular direction which will imply to control the mirror also along these directions. From the other hand the Long Recycling Cavity design is challenging because the PRM2 accuracy is very stringent (0.06 μrad) especially because this mirror will be controlled in Drift Control mode, i.e. a global control with a very narrow bandwidth of tens of mHz. Presently in Virgo+ the best accuracy obtained with the Drift control mode, used for the Input mirrors with a dithering technique, is about a fraction of μrad thus an improvement of this technique will be needed.

5 Acknowledgements

This research activity has been partially supported by Regione Toscana (Italy) through the program POR CreO FSE 2007-2013 of the European Community, within the project n. 18113 (ISAV).

¹The low accuracy needed for the transversal displacement control in L.R.C. configuration is due to the large radii of curvature for PRM2 and PRM3.

A Locking

The requirements for the angular control are different in case of locking control active or not active on the cavity lengths. This is due to the fact that the locking recovers the cavity length change induced at first order by the mirror misalignment thus the cavity power losses are due only to secondary order effects.

The following plots show the comparison of the cavity losses in case of locking active and in case of locking inactive for the PRC and SRC cavities in the Short Recycling Cavities configuration.

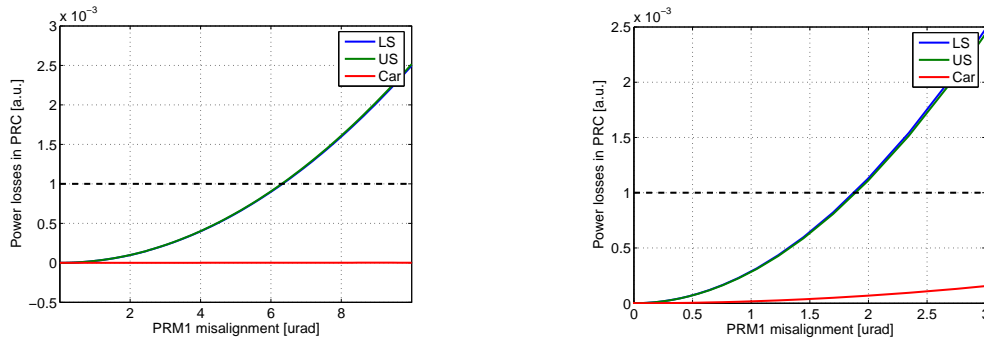

Figure 12: Comparison between the PRC power losses as a function of the PRM1 misalignment in case of lock active (left plot) and lock disactivated (right plot). In case of locking active on the cavity length the requirements are slightly relaxed as expected. The comparison has been done for the S.R.C. configuration.

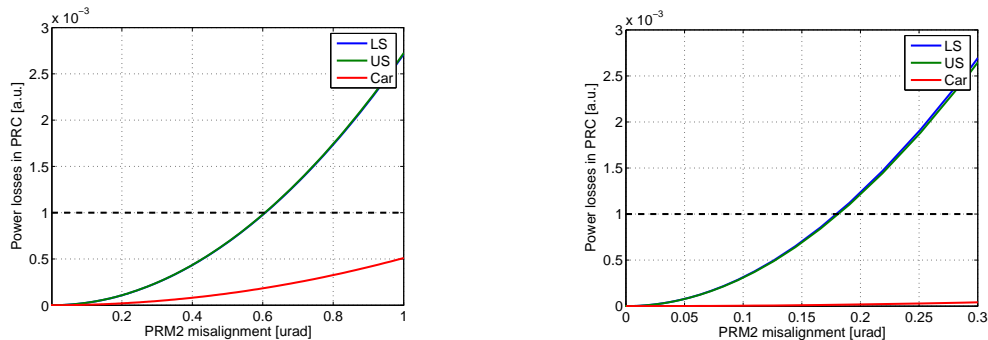

Figure 13: Comparison between the PRC power losses as a function of the PRM2 misalignment in case of lock active (left plot) and lock disactivated (right plot).

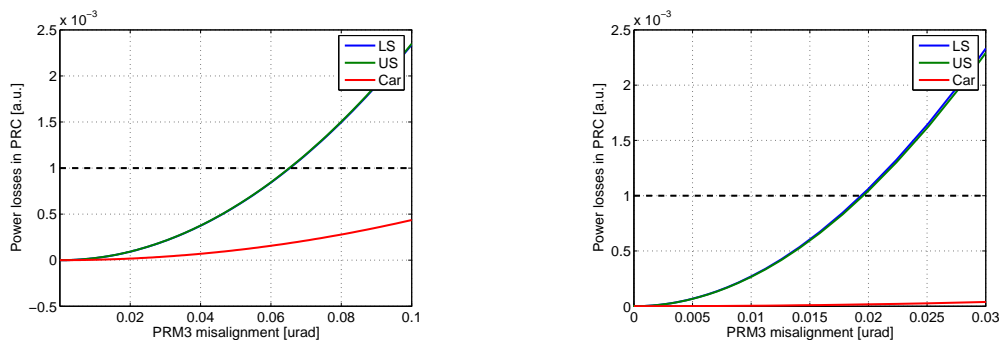

Figure 14: Comparison between the PRC power losses as a function of the PRM3 misalignment in case of lock active (left plot) and lock dis-activated (right plot)..

The angular requirements for the Power recycling mirrors are relaxed with respect the ones evaluated in the previous note [1] thanks to the locking loops active on the cavity lengths. As it is shown in Figure 12, 13 and 14 the requirements obtained in the case of locking control not active are comparable with the values found in the previous note.

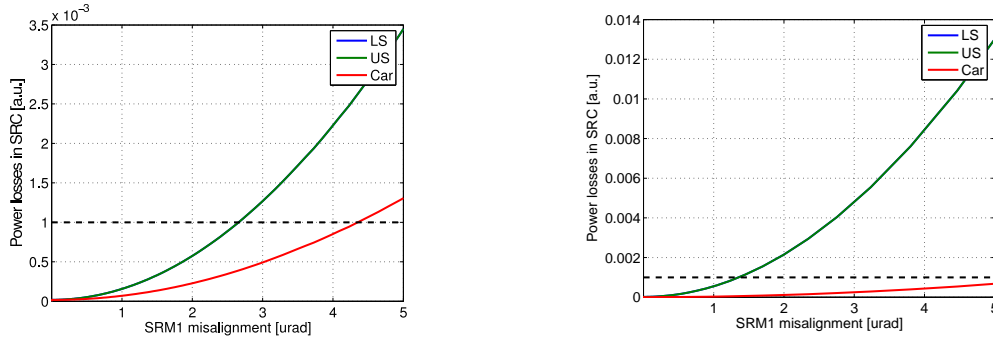

Figure 15: Comparison between the SRC power losses as a function of the SRM1 misalignment in case of lock active (left plot) and lock disactivated (right plot). In case of locking active on the cavity length the requirements are slightly relaxed as expected.

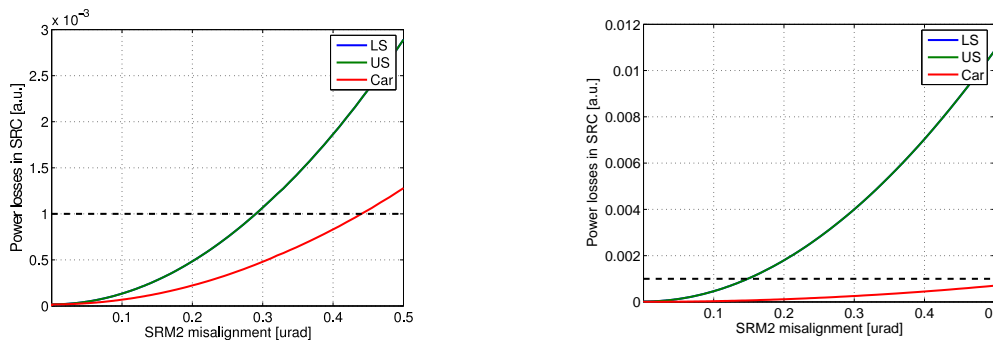

Figure 16: Comparison between the SRC power losses as a function of the SRM2 misalignment in case of lock active (left plot) and lock disactivated (right plot).

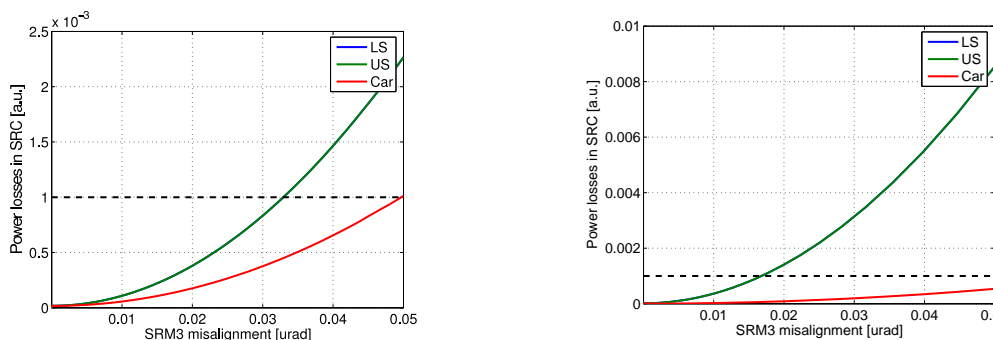

Figure 17: Comparison between the SRC power losses as a function of the SRM3 misalignment in case of lock active (left plot) and lock disactivated (right plot).

The angular requirements for the Signal recycling mirrors are relaxed with respect the ones evaluated in the previous note [1] thanks to the locking loops active on the cavity lengths. As it is shown in Figure 15, 16 and

17 the requirements obtained in the case of locking control not active are comparable with the values found in the previous note.

B pitch and yaw directions

Thanks to the possibility in Finesse to compute the effect of a misalignment in both angular directions (pitch and yaw) it is possible to compute the angular requirements in pitch and yaw directions. The comparison has been done in the Short Recycling cavity configuration (S.R.C.).

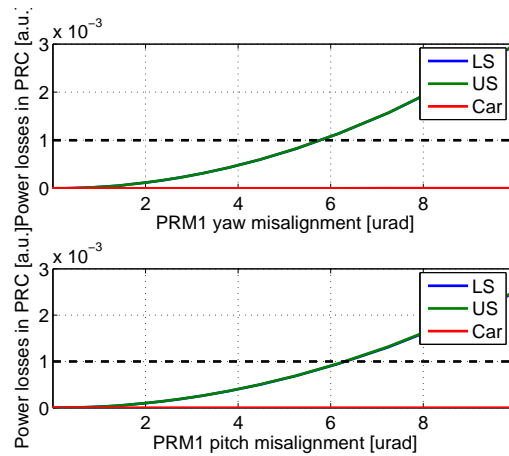

Figure 18: Comparison between the PR cavity losses as a function of the PRM1 misalignment in the yaw (top plot) and in the pitch (bottom plot) directions. The requirement in the yaw direction is a little bit more stringent (5.5 with respect to 6 μrad). It may be due to the 'Z' cavity configuration.

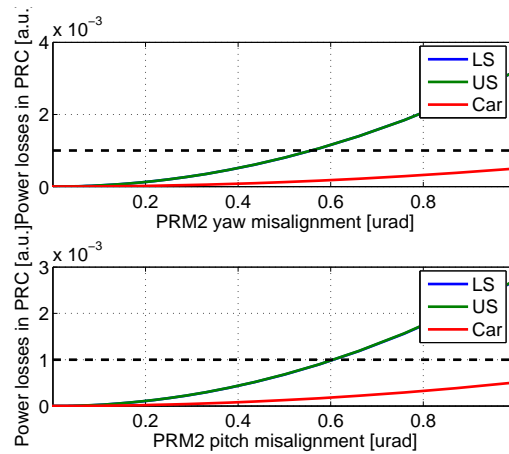

Figure 19: Comparison between the PR cavity losses as a function of the PRM2 misalignment in the yaw (top plot) and in the pitch (bottom plot) directions.

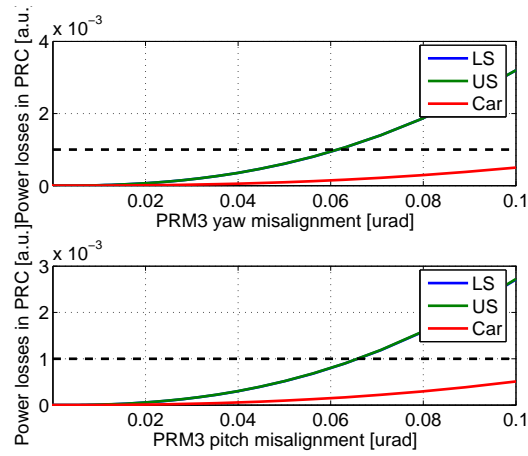

Figure 20: Comparison between the PR cavity losses as a function of the PRM3 misalignment in the yaw (top plot) and in the pitch (bottom plot) directions.

The comparison between the PR cavity losses as a function of the cavity mirror misalignment, PRM1 PRM2 and PRM3, in the yaw and in the pitch directions. The requirements in the yaw direction are slightly more stringent but still comparable. It may be due to the 'Z' cavity configuration.

C multiple mirror misalignment effect

An other item which it is interesting to evaluate is the coupling between the misalignment of the mirrors in the same recycling cavity.

For example in the Signal Recycling Cavity, for the short recycling configuration, if the first two mirrors are misaligned (SRM1 and SRM2) within the requirements the effect of the misalignment of the third mirror (SRM3) could be stronger or weaker in the sensitivity relative variation since the other mirrors misalignment could enhance or compensate its misalignment.

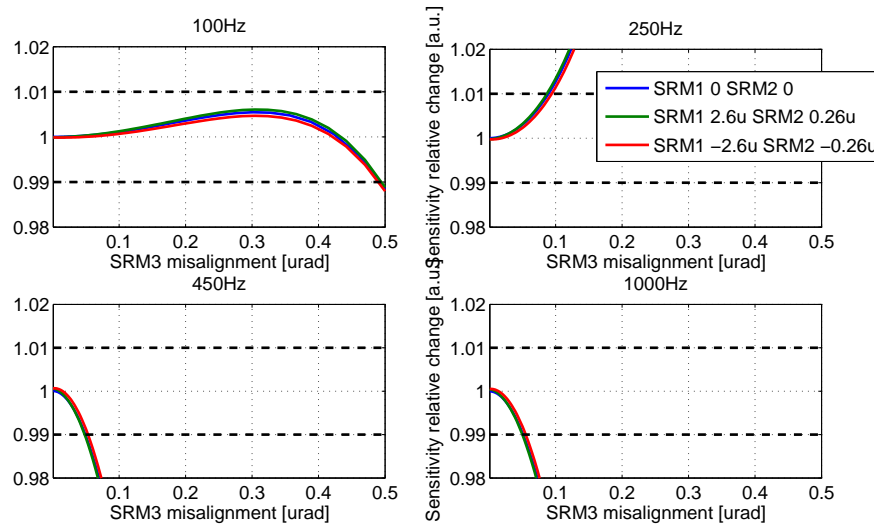

Figure 21: Effect on the SRM3 requirement of the common and differential misalignment of the other two cavity mirrors. The effect is so small that it will not taken into account.

In Figure 21 the effect of the SRM3 mirror misalignment on the sensitivity at the frequencies used to compute the requirements, i.e. 100 250 450 and 1000 Hz, with the other two mirrors aligned, differently misaligned and commonly misaligned is shown.

The effects is slightly stronger if the mirrors are commonly misaligned and is weaker than the aligned configuration is the mirrors are differently misaligned, but since the difference with respect with the aligned configuration is very small there is no reason to further check it.

References

- [1] M. Mantovani, G. Vajente “Alignment accuracy requirements for Advanced Virgo” - VIR-0247A-10 [3](#), [5](#), [13](#)
- [2] A. Freise, G. Heinzl, H. Lück, R. Schilling, B. Willke and K. Danzmann, “Frequency domain interferometer simulation with higher-order spatial modes”, *Class. Quant. Grav.* **21** (2004) S1067 [arXiv:gr-qc/0309012]. [3](#)
- [3] M. Mantovani “Draft Automatic Alignment Sensing and Control scheme for Advanced Virgo” - VIR-0323A-10