



European Commission  
*FP7, Grant Agreement 211743*



## Number of main optical components in ET

ET-0001A-11

Stefan Hild<sup>1</sup> and Andre Thüring<sup>2</sup>

*Issue:* 1

*Date:* February 4, 2011

<sup>1</sup> Institute for Gravitational Research, University of Glasgow, G12 8QQ, UK

<sup>2</sup> Max-Planck-Institut für Gravitationsphysik, Callinstrae 38, 30167 Hannover, Germany

## Contents

1	Introduction	1
2	The optical layout	1
3	Simply counting the optical elements	2

## 1 Introduction

In this document we give a very rough estimate of the number of the main optical components required for the ET baseline design. At the current stage of the ET design many detail parameters are not fixed. Therefore, we only give the 'best guesses' for the **number**, **materials** and **dimensions** of the required main optical elements.

Please note that this information is preliminary and might change significant over the next 10 years. However, the purpose of this document is to collect the information necessary to make a rough cost estimate of the optics for the ET design study.

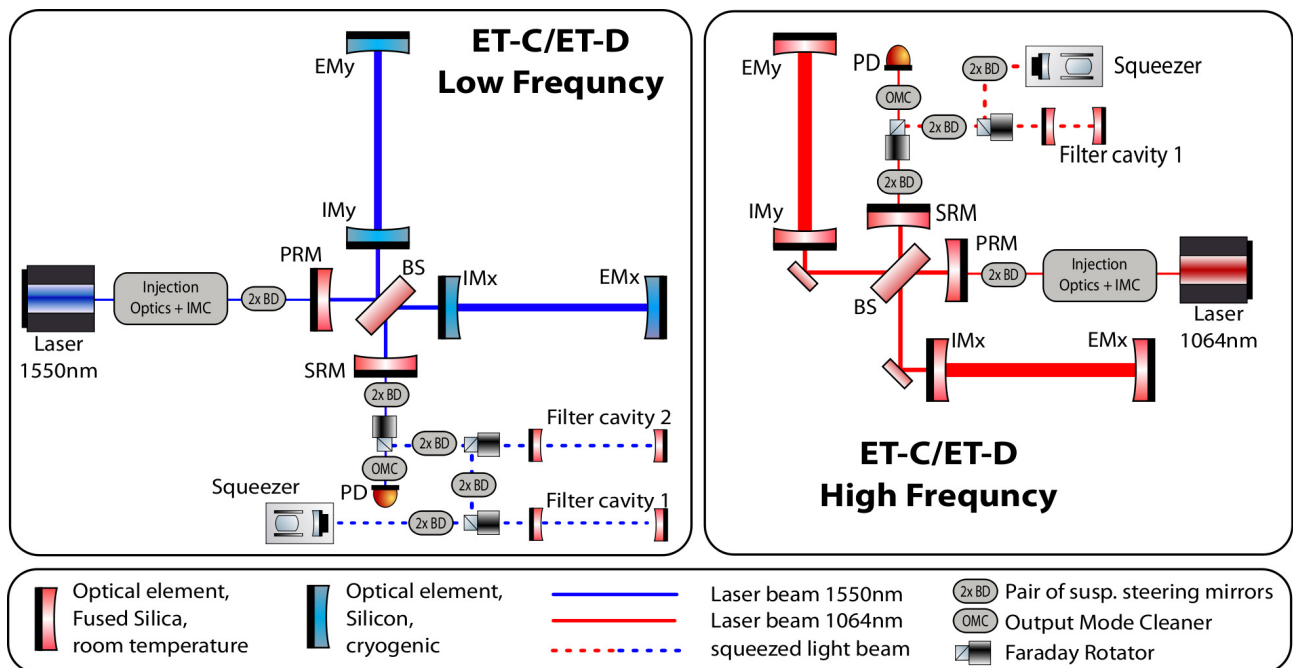

Figure 1: Simplified layout of the low and high frequency interferometers of a single ET detector.

## 2 The optical layout

A simplified schematic of a single ET detector consisting of two interferometers (one for low frequencies and one for high frequencies) is shown in Figure 1. The full ET observatory will finally consist of 3 ET detectors,

i.e. 6 interferometers in total.

In the following section we give preliminary estimates of the required *main optical elements*, which we define as all suspended optical elements between the output of the input mode cleaner (IMC) and the main photo detector(s) at the output port. This also includes parts of the squeezed light injection and the corresponding filter cavities.

### 3 Simply counting the optical elements

Tables 1 and 2 give an overview of the required optical elements for ET. The considerations given here are based on the ET-layout proposed in [1] and [2]. Therefore we consider the beam size on the optical elements around the beam splitter to be much smaller than on the main arm cavity mirrors.

The dimensions of the arm cavity mirrors have been taken from [2]. The dimensions of the recycling mirrors and most of the beam directors are not driven by the beam size at these elements, but rather are chosen to give a mirror mass, which allows to achieve low noise performance in terms of suspension, control and susceptibility. While the HF filter cavities should work with 25 cm diameter mirrors, the 10 km long filter cavities of the LF interferometer require mirrors of at least 42 cm diameter [1].

#	Dimensions (diameter / thickness)	Material	Application / remarks
4	62 cm / 30 cm	Fused Silica	Arm cavity mirrors
2	25 cm / 12.5 cm	Fused Silica	PR and SR mirrors
1	26 cm / 8 cm	Fused Silica	Main beam splitter
2	25 cm / 12.5 cm	Fused Silica	Filter cavity mirrors
2	25 cm / 12.5 cm	Fused Silica	beam directors in small michelson
8	25 cm / 12.5 cm	Fused Silica	other beam directors
1	N/A	N/A	Faraday rotator for sqz-injection
1	N/A	N/A	Output Mode Cleaner

Table 1: Main optical elements required for a **single** ET HF interferometer.

#	Dimensions (diameter / thickness)	Material	Application / remarks
4	min. 45 cm / TBD	Silicon	Arm cavity mirrors
2	25 cm / 12.5 cm	Fused Silicon	PR and SR mirrors
1	26 cm / 8 cm	Fused Silicon	Main beam splitter
4	45 cm / 20 cm	Fused Silicon	Filter cavity mirrors
10	25 cm / 12.5 cm	Fused Silicon	beam directors
2	N/A	N/A	Faraday rotator for sqz-injection
1	N/A	N/A	Output Mode Cleaner

Table 2: Main optical elements required for a **single** ET LF interferometer.

The whole ET observatory will consist of  $3 \times (24 + 21) = 135$  main optical elements.

## References

- [1] A. Freise and s. Hild: "Considerations Regarding the Optical Layout of ET", ET-0103B-10, available at <https://tds.ego-gw.it/q1/?i=ET>. 2
- [2] S.Hild *et al* "Sensitivity studies for Third Generation Gravitational Wave Observatories" accepted for publication in CQG. Also available at arXiv:1012.0908v1 [gr-qc]. 2