

# Folded pendulum dynamical behaviour in cryogenic conditions

F. Barone<sup>1,2</sup>, G. Giordano<sup>1,2</sup>, H. Vocca<sup>3,4</sup>, F. Travasso<sup>3,4,5</sup>

<sup>1</sup>University of Salerno, Italy; <sup>2</sup>INFN - sez Napoli, Italy

<sup>3</sup>University of Perugia, Italy; <sup>4</sup>INFN - sez Perugia, Italy

<sup>5</sup>European Gravitational Observatory (EGO)

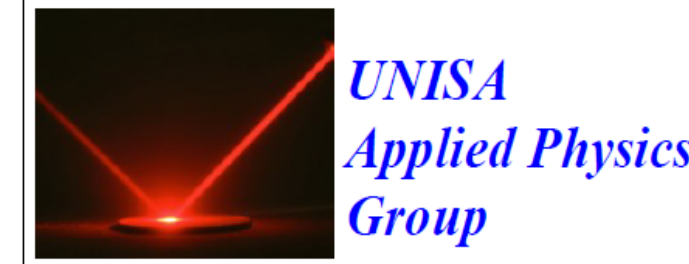

DIPARTIMENTO DI  
FISICA E GEOLOGIA  
Università degli Studi di Perugia



**GOAL:** First evaluation of the performances of the UNISA Folded Pendulum class of sensors at cryogenic conditions, for understanding advantages and limitations as sensors for measurement, control and alignment for interferometric detectors of gravitational waves of the third generation.

**SENSOR:** For the tests a standard UNISA Folded Pendulum – Model GD14 (size: 8 cm x 8 cm x 4 cm; weight: 200 g; material: Al 6082-T6 - Anticorrosive), developed for seismic measurements, equipped with a classical shadow meter readout. The sensor has been positioned within a suitably modified cryostat of the INFN Perugia, adapted to avoid unwanted recoil losses.

**TECHNIQUE:** The cryostat temperature was reduced in steps, allowing the sensor stabilization in temperature. At each step the frequency, loss angle (and, consequently, the quality factor, Q) were measured.

**PERFORMANCES:** Preliminary tests, with a not yet optimized sensor and cryostat, show the relevant decrease of the loss angle ( $\Phi \approx 8 \times 10^{-5}$ ) of the oscillator at low temperatures (125 K), corresponding to a quality factor,  $Q \approx 12000$  at the folded pendulum resonance frequency (5 Hz). This result opens a yet unexplored application field, that will be explored in more details in the next months in view of possible applications to the third generation of gravitational waves interferometric detectors.

## UNISA Folded Pendulum Extended Model

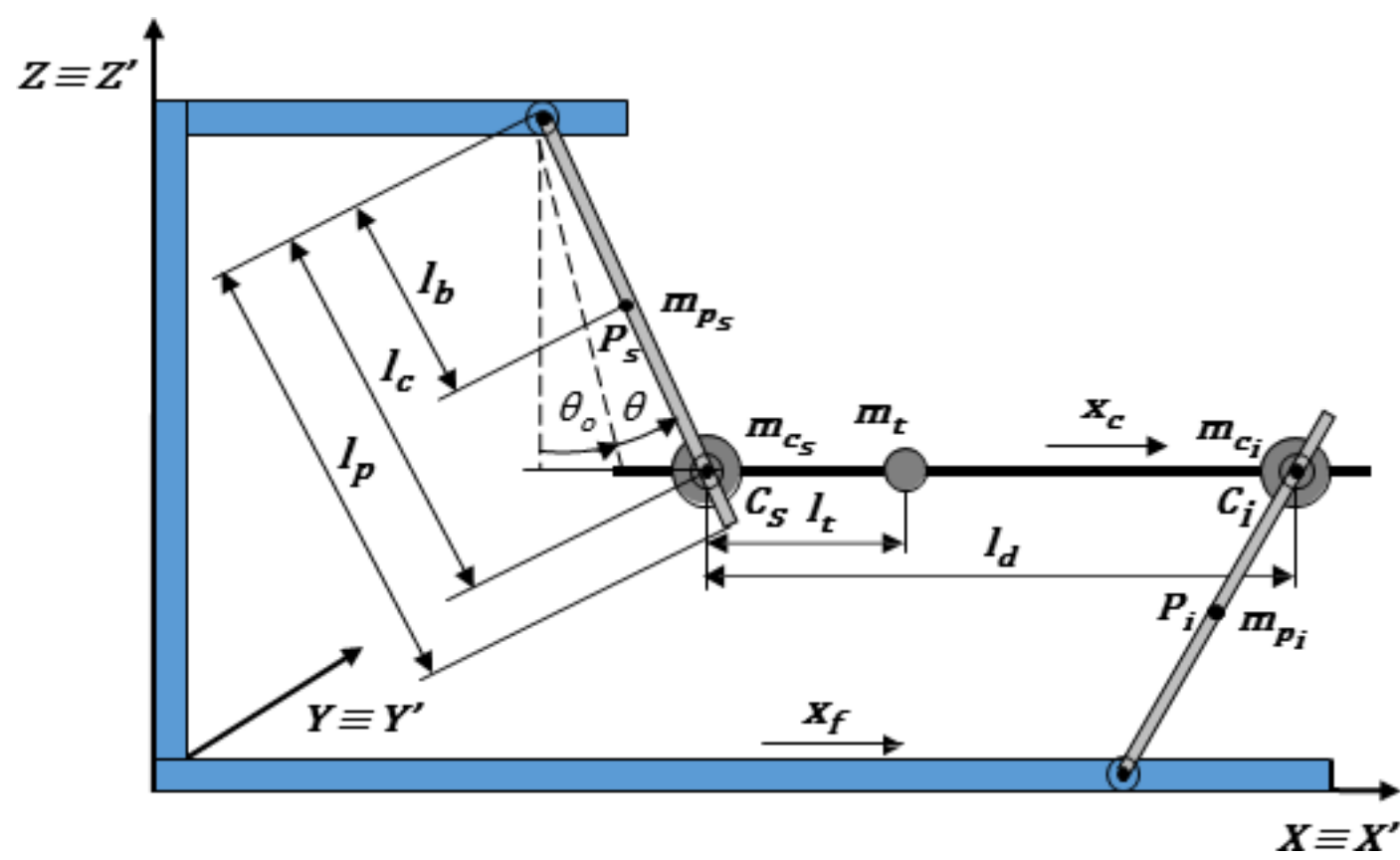

$$f_0(\alpha, \beta) = \frac{1}{2\pi} \sqrt{\frac{K_{eq}(\alpha, \beta)}{M_{eq}}} = \frac{1}{2\pi} \sqrt{\frac{K_{geq}(\alpha, \beta) + K_{eeq}}{M_{eq}}} = \frac{1}{2\pi} \sqrt{\frac{(m_{ps} - m_{pl}) \frac{l_p}{2l_c} + (m_{gs} - m_{gl}) - 2m_g \frac{M_{eq}g}{K_{eeq}d} \sin \beta}{M_{eq}} \left| \frac{g}{l_c} \cos \alpha \cos \beta + K_{eeq} \right|}$$

## Scheme of the UNISA Folded Pendulum (Model GD14) with a shadow meter readout

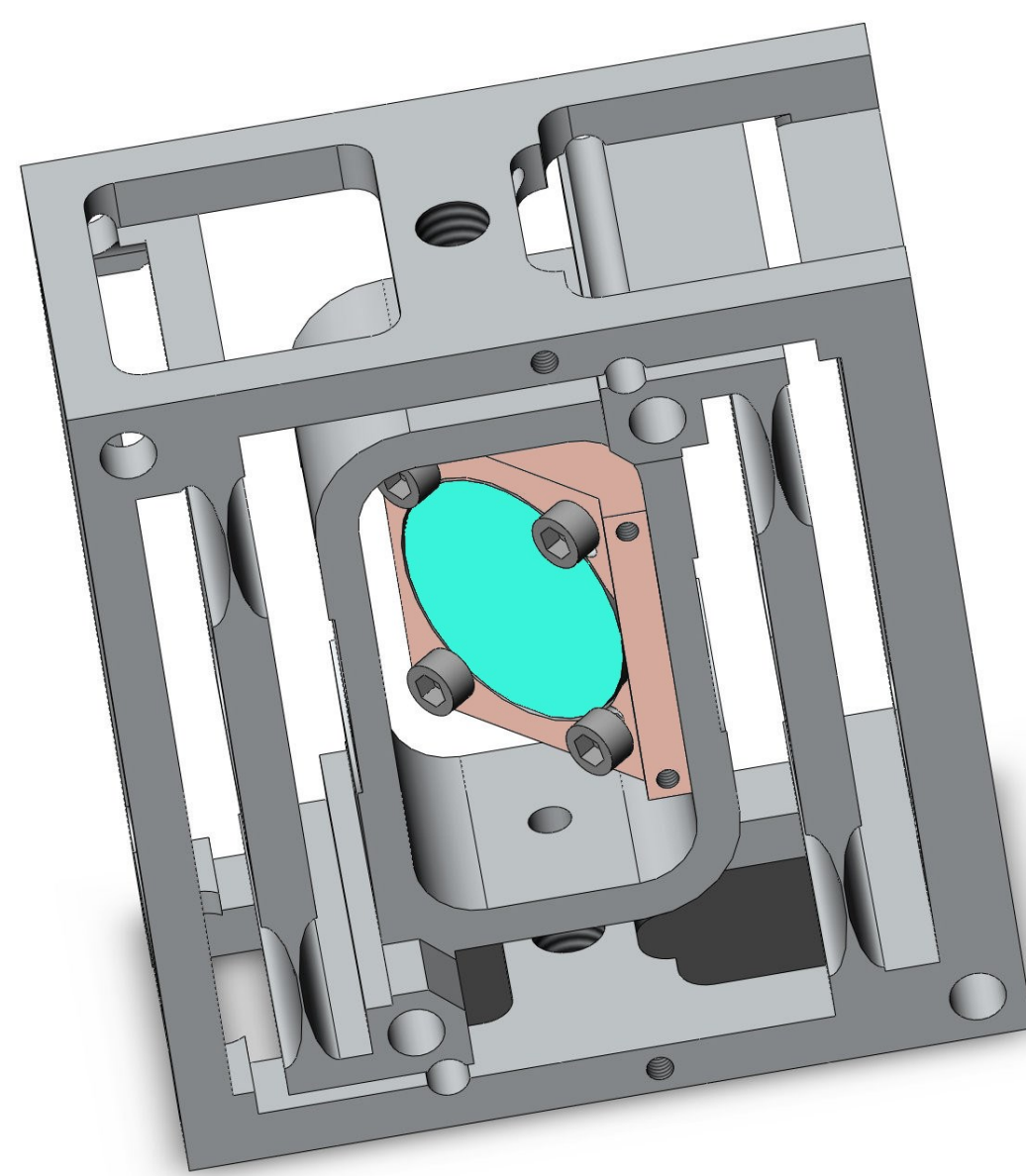

## The folded pendulum mounted on the Perugia cryostat base, modified to reduce the recoil losses

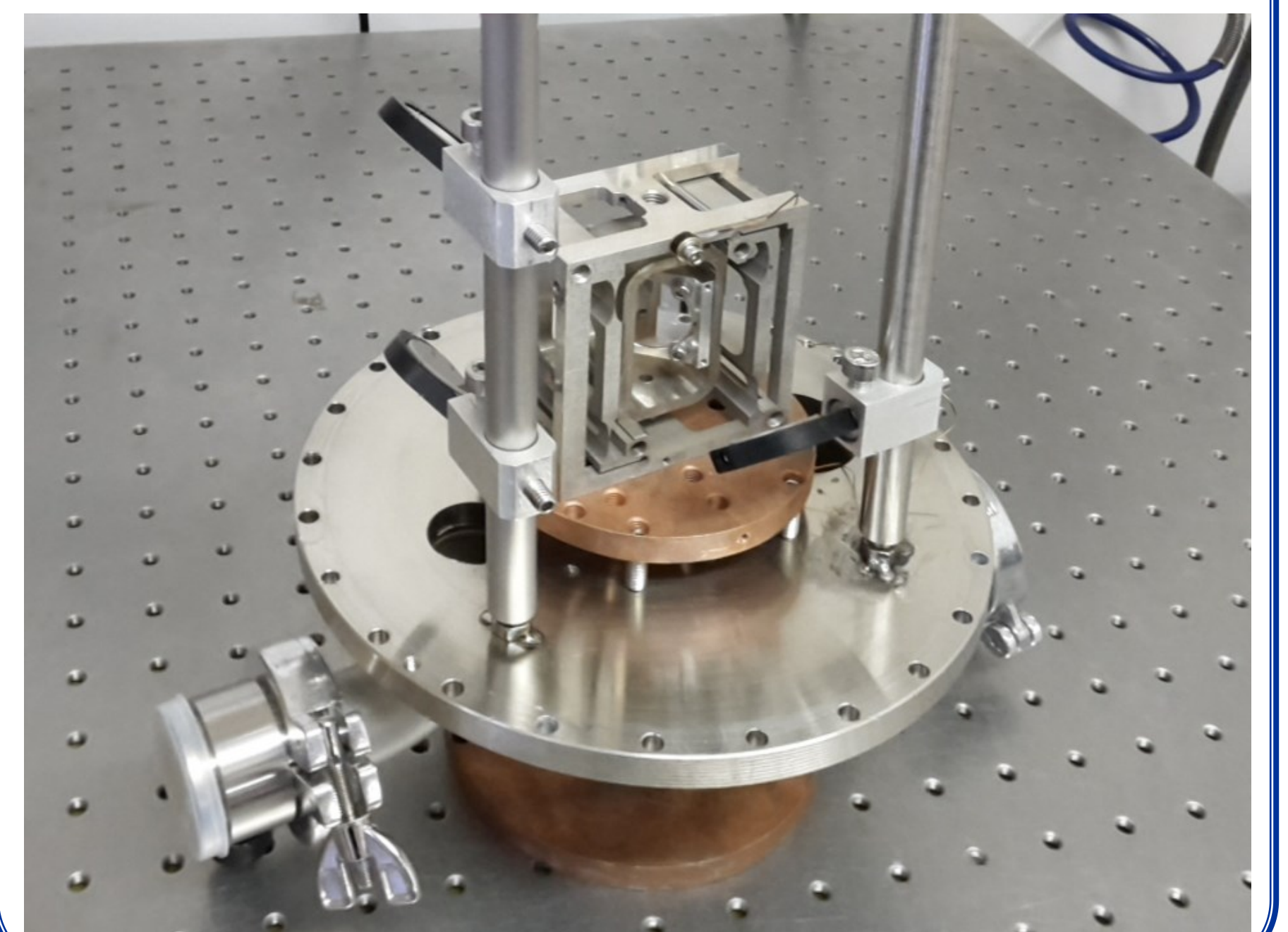

## Particular of the UNISA FP GD14

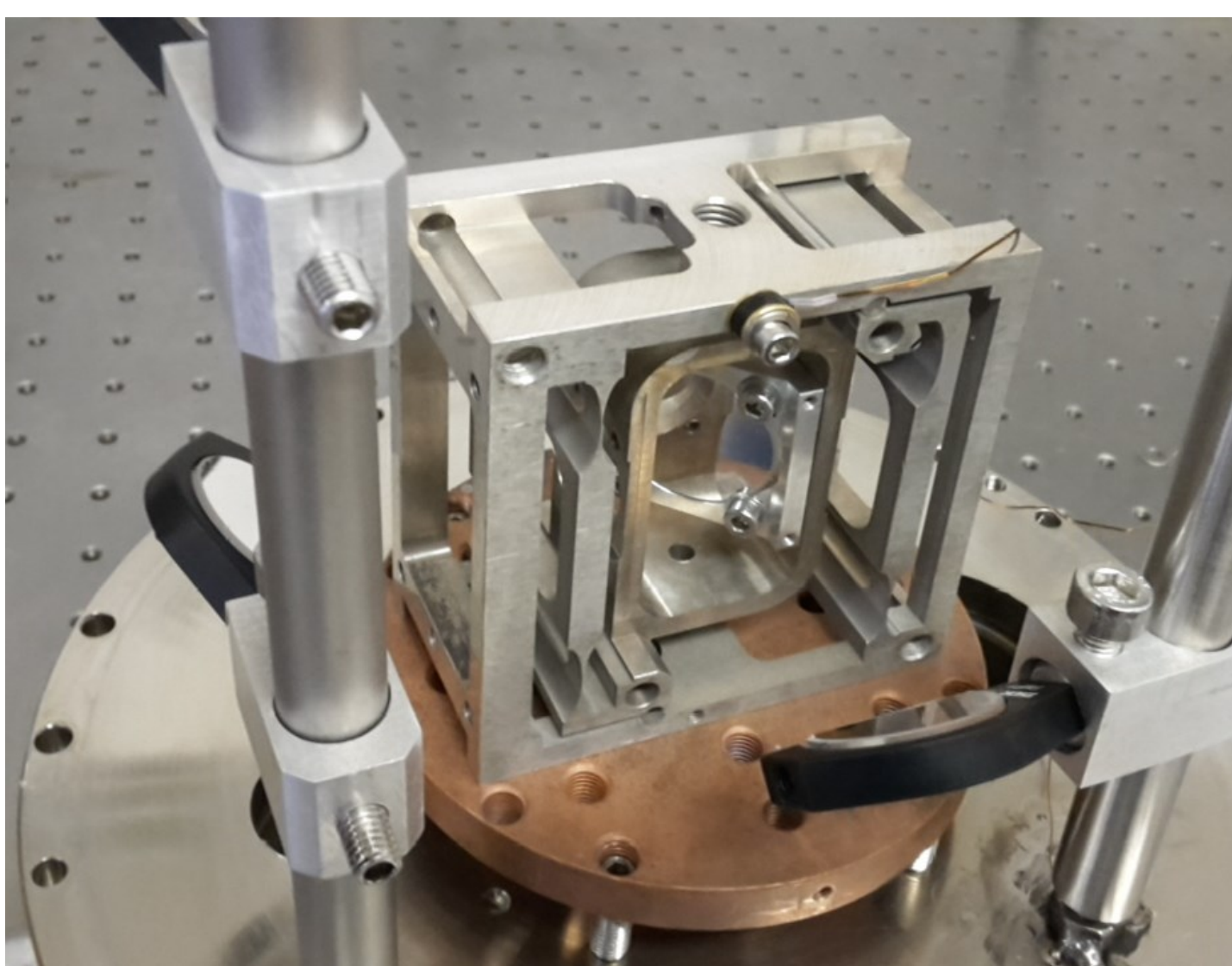

## Inertial mass oscillation amplitude decay at different temperatures

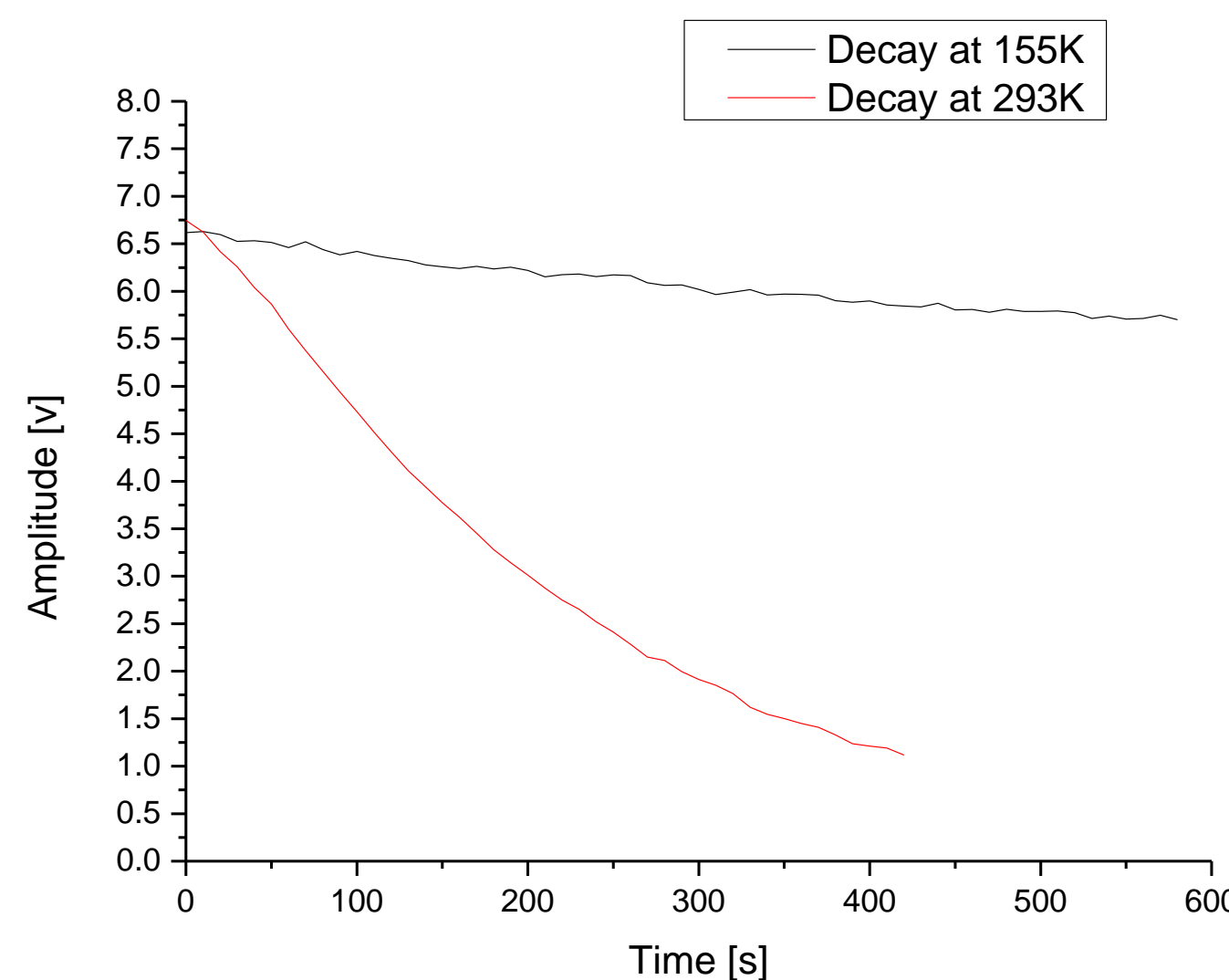

## Conclusion

- The aim of the preliminary tests presented here has been to demonstrate, for the first time, the large enhancement of the performances of the UNISA Folded Pendulum configured as inertial seismometer.
- Although the sensor used (GD14) and the cryostat are not yet optimized, a sensor loss angle  $\Phi \approx 8 \times 10^{-5}$  has been measured at a temperature  $T = 125$  K for a resonance frequency  $f_0 = 5$  Hz. This measurement corresponds to a quality factor  $Q \approx 12000$  !!
- Further tests with optimized monolithic UNISA folded pendulums, tuned at lower frequencies ( $< 200$  mHz), and with an optimized cryostat are planned, such as simulations aimed to the optimizations of the UNISA Folded Pendulum performances for cryogenics applications.
- These results, although very preliminary, demonstrate that the UNISA Folded Pendulum may become a good candidate as sensor for cryogenic applications, in view of the implementation of interferometric detectors of gravitational waves of the third generation.

## Folded Pendulum total Losses vs. Temperature

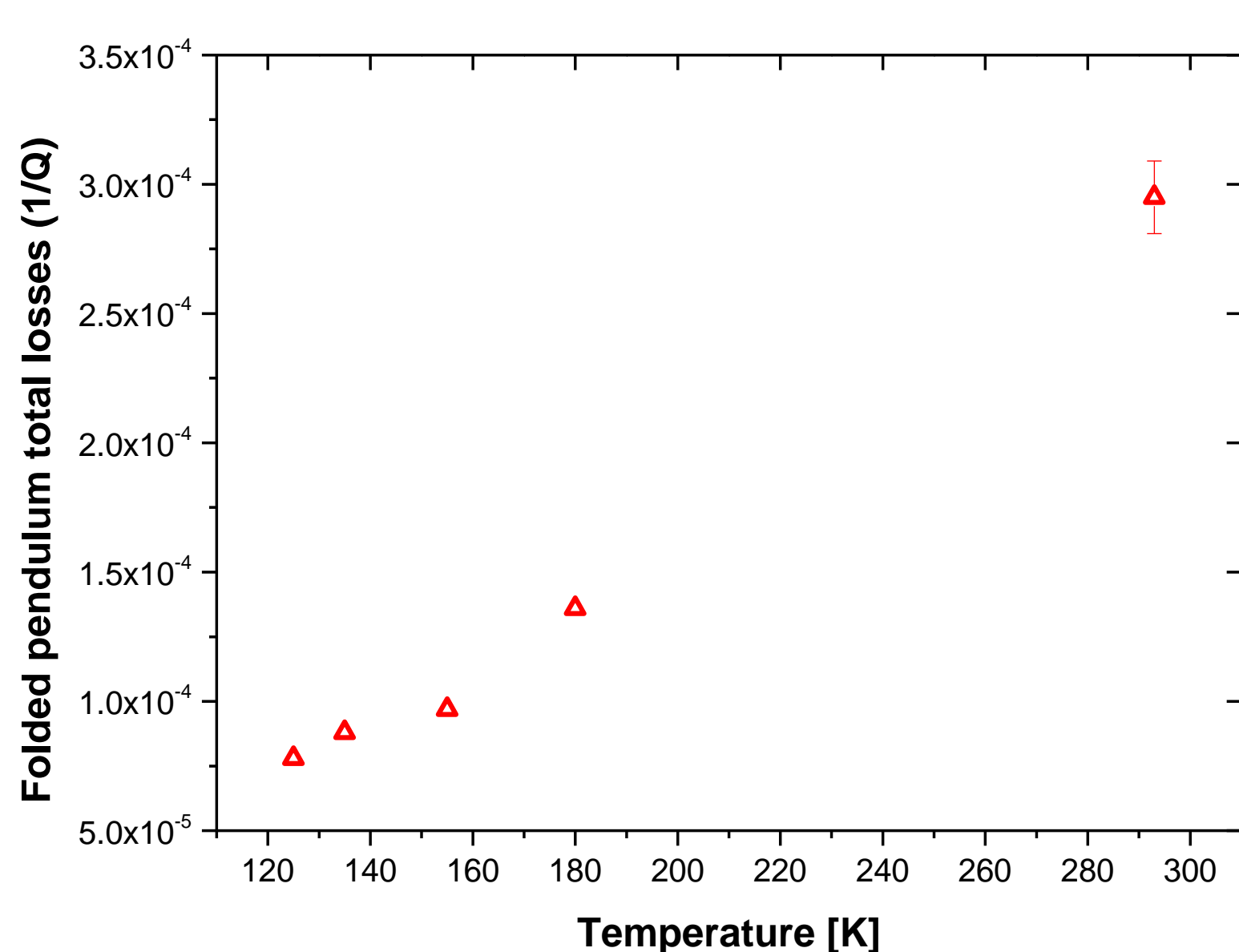

## Folded Pendulum Quality Factor vs. Temperature

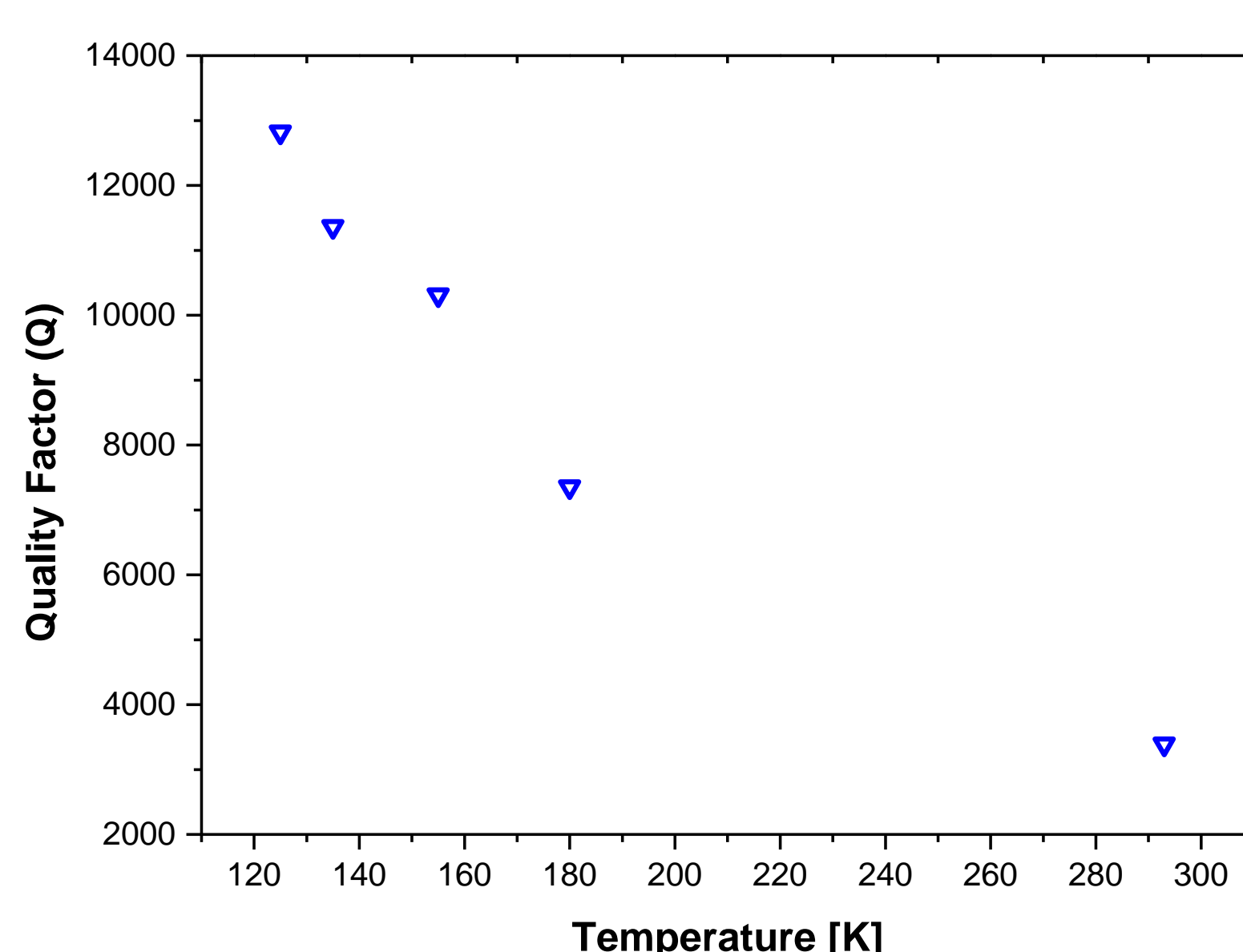

## ACKNOWLEDGMENTS

The authors acknowledge Beneforti Donatella & C. S.n.c. for the technical support and the implementation of the mechanics of the monolithic folded pendulum sensors.

