



## ALS Test 1: Arm cavities actuation chain

VIR-0381A-20

Julia Casanueva<sup>1\*</sup>, Antonino Chiummo<sup>1</sup>, Matthieu Gosselin<sup>2</sup>, Nicolas Leroy<sup>3</sup>, Alain Masserot<sup>4</sup>, Beatrice Montanari<sup>1</sup>, Flavio Nocera<sup>1</sup>, Camila de Rossi<sup>1</sup>, and Marco Vardaro<sup>5</sup>

<sup>1</sup>*European Gravitational Observatory, EGO*

<sup>2</sup>*INFN Sezione di Pisa*

<sup>3</sup>*IJCLab*

<sup>4</sup>*LAPP*

<sup>5</sup>*Nikhef*

*Date:* April 23, 2020

[\*] *corresponding author:* [julia.casanueva@pi.infn.it](mailto:julia.casanueva@pi.infn.it)



## Contents

<b>1</b>	<b>Introduction</b>	<b>2</b>
<b>2</b>	<b>Experimental setup</b>	<b>2</b>
<b>3</b>	<b>Lock and calibration</b>	<b>3</b>
<b>4</b>	<b>Actuator characterization</b>	<b>4</b>
<b>5</b>	<b>Conclusion</b>	<b>5</b>
	<b>References</b>	<b>5</b>

# 1 Introduction

The target of this test was to characterize the actuation chain that will be used for the lock of the green lasers to the arm cavities (including the controls and the DAC), which will be the first step of the lock acquisition once the Signal Recycling Mirror is installed. At first, the lock acquisition will be done by changing the frequency of the green laser, using the AOM that shifts the infrared beam by 80 MHz. For that purpose a VCO will be used, which has a frequency tuning constant of 4 MHz/V [1].

The arm cavities have a linewidth of 263 Hz for the green laser, which means that the actuation chain needs to be able to make changes smaller than that. To be conservative, a factor 10 will be considered as the minimum step that needs to be done by the actuators. Notice that in spite of this attenuation, the actuator is still able to scan a FSR of the cavity.

However, in order to make a step of 25 Hz for the green, the needed voltage would be  $3 \mu\text{V}$ . The DACs used for the controls are 18-bits, with a range of  $\pm 10 \text{ V}$ , which means that, taking in account potential noises (16 effective bits), the minimum step that can be done with them is  $300 \mu\text{V}$ . It is then necessary to divide this noise by a factor 100 and, at the same time, keep the VCO control voltage around the level that guarantees its output frequency will stay close to the nominal 80 MHz required by the AOM. This is done with a dedicated electronics, aka the VCO Driver represented as a divider in the block diagrams that follow (Figure 1). The EGO Electronics Group prepared it.

The test has been used to characterize the DAC, the VCO, its driver and the AOM working together, implement a first version of the control logic with the fast DSP that will be used and measure the smallest step that can be done with the final setup.

# 2 Experimental setup

For testing the actuator an optical cavity is needed, in particular the spare Pre-Mode Cleaner (PMC) has been used. The main difference with the arm cavities is its linewidth, which is much larger for the PMC 1MHz. This means that the actuation chain to be tested will have too small dynamics for this cavity (40 kHz/V only). One of the advantages of using the PMC is that it has a PZT actuator to modify its length, which will provide enough dynamics for the control, allowing to test the AOM, which is the scope of the setup.

The second advantage is that the optical setup for controlling the cavity was already built, it was only necessary to add the AOM to be tested and to replace the photodiode in reflection by one compatible with digital demodulation. The frequency chosen was 25 MHz, since in that region the noise floor of the photodiode was lower.

All the controls have been written using the same type of fast DSP that will be used in the arms. A scheme of the setup can be found in Figure 1.

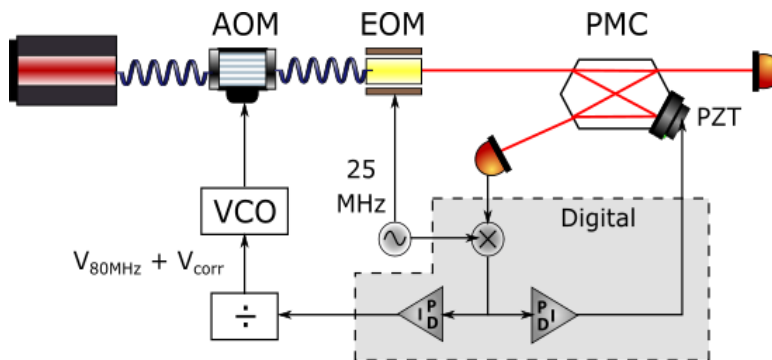

Figure 1: Scheme of the setup.

The strategy chosen for the control acquisition was to first scan with the PZT actuator the length of the cavity, around a resonance. Then, a trigger was implemented, that would look at the height of the transmission peak and, if it is higher than 60% of the maximum transmitted power, the lock would be engaged. At first, only the PZT actuator was used to lock the cavity, with a low bandwidth, and then a manual switch was used to engage the control using also the AOM.

### 3 Lock and calibration

The first step was to engage the control of the PMC using the PZT actuator. The filter was designed to have a low UGF, since the main role of the PZT was to share the corrections needed to lock, to avoid the saturation of the AOM.

A scheme of the system is shown in Figure 2. The transfer function of the PMC is a simple pole at half its linewidth, so it can be considered flat in the frequency range of the experiment (up to 50 kHz). The same thing applies to the PZT. In order to characterize this first loop and its elements, the OLTF of the system has been

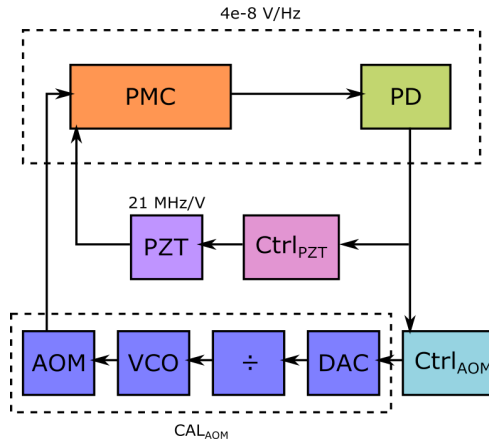

Figure 2: Scheme of the control loop. The error signal is sent to two different actuators: the PZT at low frequency and the AOM at high frequency. The calibration factors obtained from the measurements are also shown.

measured by adding colored noise to the error signal. Figure 3 shows the measurement compared to the model just described, confirming an UGF around 25 Hz. They are in agreement, which confirms that there are no unexplained structures on the system.

This measurement allows to calculate the calibration factor of the PMC and the photodiode:  $4e-8$  V/Hz, which, in turn, allows to calibrate the error signal in Hz:  $Cal_{err} = 25$  MHz/V. The delay necessary to reproduce the measurement is  $550$   $\mu$ s.

Once the plant (PMC + PD) has been characterized, the next step was to use the AOM as the second actuator. As the error signal was the same for both actuators, the loop of the AOM was designed to be compliant with the stability requirements of a nested loop. Figure 4 shows the model of the two control loops and the global one. The global loop was designed to have an UGF around 10 kHz, and the actuators will cross around 10 Hz.

The loop was engaged using both actuators confirming the compatibility between the control hardware and the actuation chain. It was also used to prepare the control algorithm plus the structure used for the noise injections. In this configuration a new noise injection was made which is shown in Figure 5. In this case the model is also confirmed by the measurements, and the measured delay of the loop is of  $9$   $\mu$ s, which is lower than the one measured on the loop of the SSFS, which uses the same DSP ( $11$   $\mu$ s in that case [2]).

This measurement also allowed to calibrate the actuation chain of the AOM. The measurement shown in Figure 5 corresponds to a calibration of 100 kHz/V, but the setup has been tested with a calibration of 20 kHz/V and 1 MHz/V. The measured factors are in agreement with the expected values. In particular we have used the last

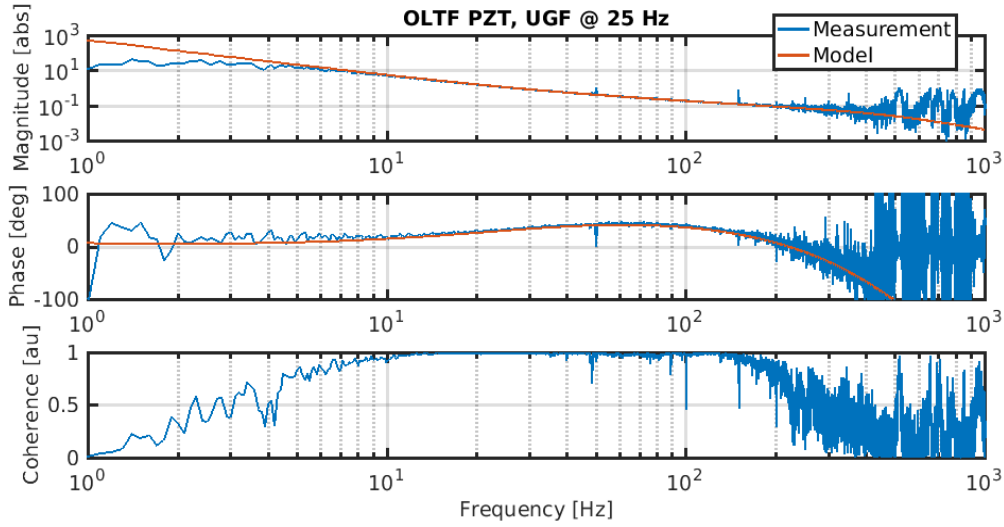

Figure 3: Open Loop Transfer Function of the control loop using the PZT actuator only. The measurement is in good agreement with the model, and the measured UGF is 25 Hz.

Amplitude	TF magnitude	TF phase	Coherence
1e-5	0	0	0
2e-5	0	0	0
4e-5	7.5e-3	0.7	0.7
5e-5	1e-2	-2.5	0.8
1e-4	1.6e-2	-2.4	0.9
2e-4	2.2e-2	-2.4	0.9
1e-3	2.2e-2	-2.4	0.9

Table 1: Measurements done for a sine injected at 8726 Hz at different line amplitudes. The TF values converge starting from 2e-4 V.

one to check the smallest step that the system could do, since this was the noisiest configuration, and so the measurement was easier.

## 4 Actuator characterization

In the last part of the test, the actuator smallest step has been measured. Using only the PZT as actuator, a sine at 8726 Hz has been added to the AOM with different amplitudes. This frequency has been chosen in a part of the spectrum with low level of noise. The transfer function between the injected line as seen in the correction sent to the actuation chain and the line as seen by the error signal, has been used to determine the smallest step. When the actuation chain is not limited by the DAC noise, the TF between the correction and the error signal is constant, since the response is linear. An example of this measurements is shown in Figure 6.

The amplitude of this sine has been reduced until the coherence between the correction sent and the error signal starts to decrease and the ratio is not linear anymore. This measurements show that the lower step that can be done is 2e-4 V, which, with the attenuation factor that is foreseen (20 kHz/V), means that the minimum step that can be done is 8 Hz. Table 1 shows the results of the measurements.

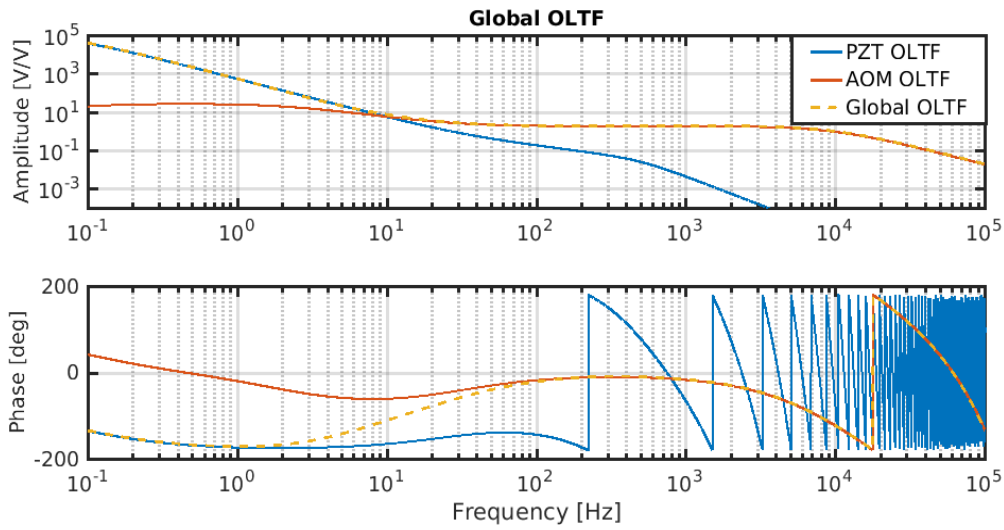

Figure 4: Model of the Open Loop Transfer Function of the system when using the PZT only (blue), when using the AOM only (red) and when using both of them at the same time, which is the final configuration (yellow).

## 5 Conclusion

This test was used to proof that the actuation chain that will be used for the lock of the arm cavities fulfills the requirements. In particular it has been measured that the smallest step that is able to do is 8 Hz. Also, it was possible to test the DSP that will be used for the arm cavities, and a preliminary algorithm.

## References

- [1] VCO ZX95-78+, URL:<https://www.minicircuits.com/pdfs/ZX95-78+.pdf> 2
- [2] Logbook entry #41535 3

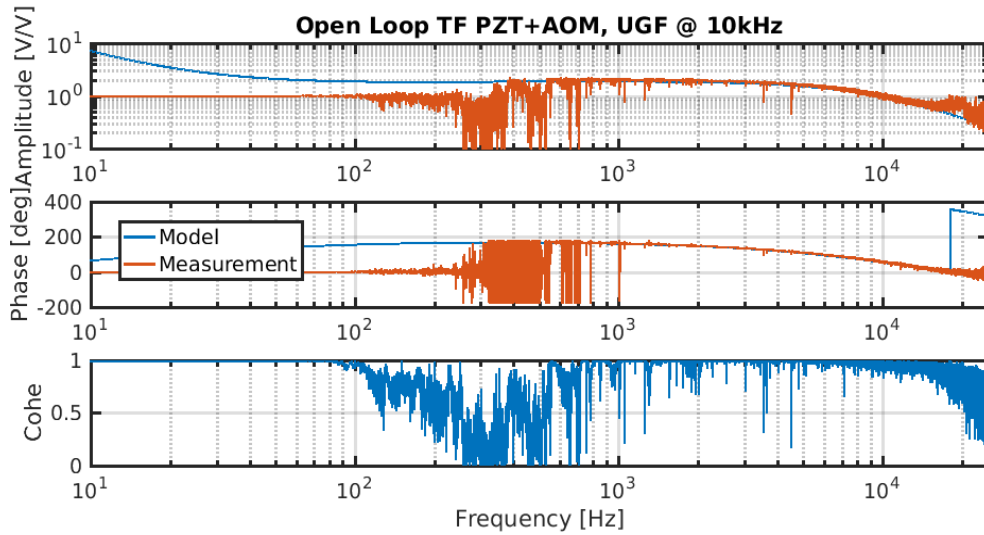

Figure 5: Open Loop Transfer Function of the control loop using the PZT and the AOM as actuators. The measurement is in good agreement with the model, and the measured UGF is 10 kHz.

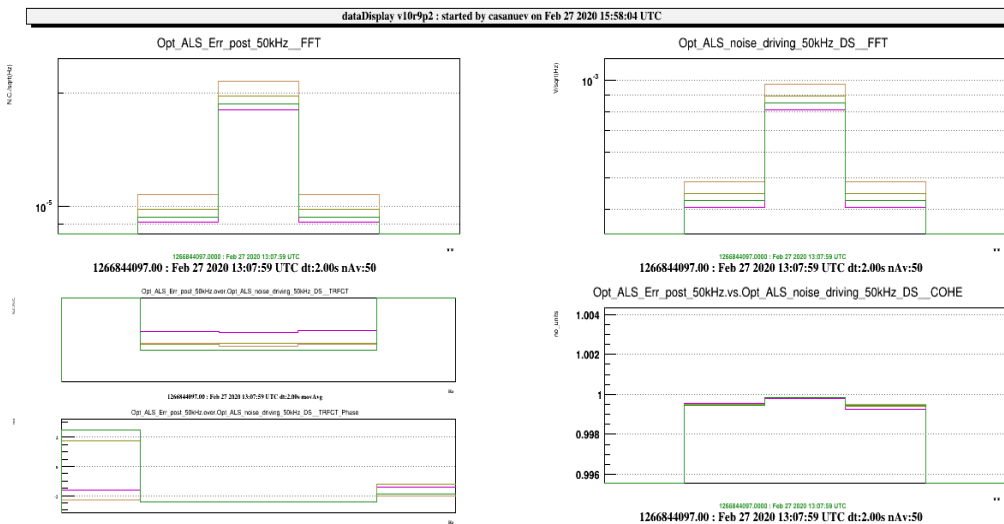

Figure 6: Spectrum of the error signal, of the correction sent, transfer function between them and coherence between them. All the graphs are zoomed around the injected line, at 8726 Hz. There are four lines shown, for different amplitudes of the lines: 1e-3 V (pink), 1.05e-3 V (green), 1.1e-3 V (light green) and 1.2e-3 V (yellow).